

1.25A, 4MHz, Synchronous Step-Down DC/DC Converter

April 2002

FEATURES

- Small 10-Lead MSOP Package
- Uses Tiny Capacitors and Inductor
- High Frequency Operation: Up to 4MHz
- High Switch Current: 1.6A
- Low $R_{DS(ON)}$ Internal Switches: 0.110 Ω
- High Efficiency: Up to 95%
- Stable with Ceramic Capacitors
- Current Mode Operation for Excellent Line and Load Transient Response
- Short-Circuit Protected
- Low Dropout Operation: 100% Duty Cycle
- Low Shutdown Current: $I_Q \leq 1\mu A$
- Low Quiescent Current: 60 μA
- Output Voltages from 5V to 0.8V
- Selectable Burst Mode[®] Operation
- Synchronizable to External Clock

APPLICATIONS

- Notebook Computers
- Digital Cameras
- Cellular Phones
- Handheld Instruments

DESCRIPTION

The LTC[®]3411 is a constant frequency, synchronous, step-down, DC/DC converter. Intended for medium power applications, it operates from a 2.5V to 5.5V input voltage range and has a user configurable operating frequency up to 4MHz, allowing the use of tiny, low cost capacitors and inductors 2mm or less in height. The output voltage is adjustable from 0.8V to 5V. Internal synchronous 0.11 Ω power switches with 1.6A peak current ratings provide high efficiency. The LTC3411's current mode architecture and OPTI-LOOP[®] compensation allow the transient response to be optimized over a wide range of loads and output capacitors.

The LTC3411 can be configured for automatic power saving Burst Mode operation to reduce gate charge losses when the load current drops below the level required for continuous operation. For reduced noise and RF interference, the SYNC/MODE pin can be configured to skip pulses or provide forced continuous operation.

To further maximize battery life, the P-channel MOSFET is turned on continuously in dropout (100% duty cycle) with a low quiescent current of 60 μA . In shutdown, the device draws <1 μA .

LT, LTC and LT are registered trademarks of Linear Technology Corporation.
 Burst Mode and OPTI-LOOP are registered trademarks of Linear Technology Corporation.

TYPICAL APPLICATION

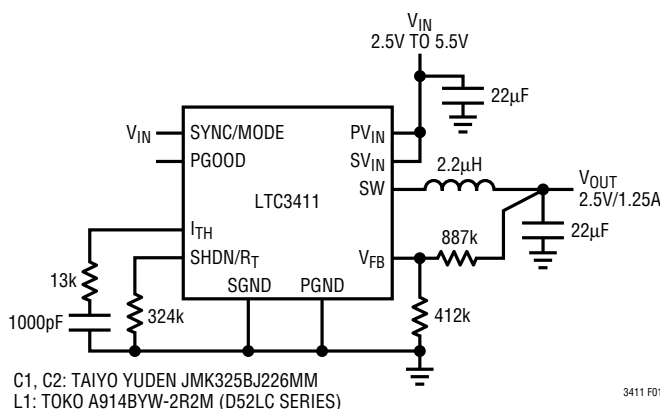
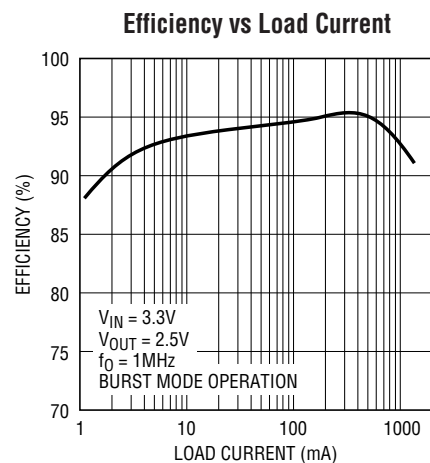

Figure 1. Step-Down 2.5V/1.25A Regulator



ABSOLUTE MAXIMUM RATINGS

(Note 1)

V_{IN} , SV_{IN} Voltages	-0.3V to 6V
V_{FB} , I_{TH} , SHDN/ R_T Voltages	-0.3V to ($V_{IN} + 0.3V$)
SYNC/MODE Voltage	-0.3V to ($V_{IN} + 0.3V$)
SW Voltage	-0.3V to ($V_{IN} + 0.3V$)
PGOOD Voltage	-0.3V to 6V
Operating Temperature Range (Note 2) ..	-40°C to 85°C
Junction Temperature (Note 5)	125°C
Storage Temperature Range	-65°C to 150°C
Lead Temperature (Soldering, 10 sec)	300°C

PACKAGE/ORDER INFORMATION

	ORDER PART NUMBER
	LTC3411EMS
	MS PART MARKING
	LTQT

Consult LTC Marketing for parts specified with wider operating temperature ranges.

ELECTRICAL CHARACTERISTICS

The ● denotes the specifications which apply over the full operating temperature range, otherwise specifications are at $T_A = 25^\circ\text{C}$. $V_{IN} = 3.3V$, $R_T = 324k$ unless otherwise specified. (Note 2)

SYMBOL	PARAMETER	CONDITIONS	MIN	TYP	MAX	UNITS
V_{IN}	Operating Voltage Range		2.625		5.5	V
I_{FB}	Feedback Pin Input Current	(Note 3)			± 0.1	μA
V_{FB}	Feedback Voltage	(Note 3)	● 0.784	0.8	0.816	V
$\Delta V_{LINEREG}$	Reference Voltage Line Regulation	$V_{IN} = 2.7V$ to $5V$		0.04	0.2	%/V
$\Delta V_{LOADREG}$	Output Voltage Load Regulation	$I_{TH} = 0.36$, (Note 3)	●	0.02	0.2	%
		$I_{TH} = 0.84$, (Note 3)	●	-0.02	-0.2	%
$g_{m(EA)}$	Error Amplifier Transconductance	I_{TH} Pin Load = $\pm 5\mu\text{A}$ (Note 3)		800		μS
I_S	Input DC Supply Current (Note 4)					
	Active Mode	$V_{FB} = 0.75V$, SYNC/MODE = $3.3V$		240	350	μA
	Sleep Mode	$V_{SYNC/MODE} = 3.3V$, $V_{FB} = 1V$		62	100	μA
	Shutdown	$V_{SHDN/RT} = 3.3V$		0.1	1	μA
$V_{SHDN/RT}$	Shutdown Threshold High			$V_{IN} - 0.6$	$V_{IN} - 0.4$	V
	Active Oscillator Resistor			324k	1M	Ω
f_{OSC}	Oscillator Frequency	$R_T = 324k$ (Note 7)	0.85	1	1.15	MHz
					4	MHz
f_{SYNC}	Synchronization Frequency	(Note 7)	0.4		4	MHz
I_{LIM}	Peak Switch Current Limit	$I_{TH} = 1.3$	1.6	2		A
$R_{DS(ON)}$	Top Switch On-Resistance (Note 6)	$V_{IN} = 3.3V$		0.11	0.15	Ω
	Bottom Switch On-Resistance (Note 6)	$V_{IN} = 3.3V$		0.11	0.15	Ω
$I_{SW(LKG)}$	Switch Leakage Current	$V_{IN} = 6V$, $V_{I_{TH}/RUN} = 0V$, $V_{FB} = 0V$		0.01	1	μA
V_{UVLO}	Undervoltage Lockout Threshold	V_{IN} Ramping Down	2.375	2.5	2.625	V
PGOOD	Power Good Threshold	V_{FB} Ramping Up, SHDN/ $R_T = 1V$		6.8		%
		V_{FB} Ramping Down, SHDN/ $R_T = 1V$		-7.6		%
R_{PGOOD}	Power Good Pull-Down On-Resistance			118	200	Ω

ELECTRICAL CHARACTERISTICS

Note 1: Absolute Maximum Ratings are those values beyond which the life of a device may be impaired.

Note 2: The LTC3411E is guaranteed to meet specified performance from 0°C to 70°C. Specifications over the –40°C to 85°C operating temperature range are assured by design, characterization and correlation with statistical process controls.

Note 3: The LTC3411 is tested in a feedback loop which servos V_{FB} to the midpoint for the error amplifier ($V_{ITH} = 0.6V$).

Note 4: Dynamic supply current is higher due to the internal gate charge being delivered at the switching frequency.

Note 5: T_J is calculated from the ambient T_A and power dissipation P_D according to the following formula: $T_J = T_A + (P_D \cdot 120^\circ C/W)$

Note 6: Switch on-resistance is guaranteed by correlation to wafer level measurements.

Note 7: 4MHz operation is guaranteed by design but not production tested and is subject to duty cycle limitations (see Applications Information).

PIN FUNCTIONS

SHDN/R_T (Pin 1): Combination Shutdown and Timing Resistor Pin. The oscillator frequency is programmed by connecting a resistor from this pin to ground. Forcing this pin to SV_{IN} causes the device to be shut down. In shutdown all functions are disabled.

SYNC/MODE (Pin 2): Combination Mode Selection and Oscillator Synchronization Pin. This pin controls the operation of the device. When tied to SV_{IN} or SGND, Burst Mode operation or pulse skipping mode is selected, respectively. If this pin is held at half of SV_{IN} , the forced continuous mode is selected. The oscillation frequency can be synchronized to an external oscillator applied to this pin. When synchronized to an external clock pulse skip mode is selected.

SGND (Pin 3): The Signal Ground Pin. All small signal components and compensation components should be connected to this ground (see Board Layout Considerations).

SW (Pin 4): The Switch Node Connection to the Inductor. This pin swings from PV_{IN} to PGND.

PGND (Pin 5): Main Power Ground Pin. Connect to the (–) terminal of C_{OUT} , and (–) terminal of C_{IN} .

PV_{IN} (Pin 6): Main Supply Pin. Must be closely decoupled to PGND.

SV_{IN} (Pin 7): The Signal Power Pin. All active circuitry is powered from this pin. Must be closely decoupled to SGND. SV_{IN} must be greater than or equal to PV_{IN} .

PGOOD (Pin 8): The Power Good Pin. This common drain logic output is pulled to SGND when the output voltage is not within $\pm 7.5\%$ of regulation.

V_{FB} (Pin 9): Receives the feedback voltage from the external resistive divider across the output. Nominal voltage for this pin is 0.8V.

I_{TH} (Pin 10): Error Amplifier Compensation Point. The current comparator threshold increases with this control voltage. Nominal voltage range for this pin is 0V to 1.5V.

PIN	NAME	DESCRIPTION	NOMINAL (V)			ABSOLUTE MAX (V)	
			MIN	TYP	MAX	MIN	MAX
1	SHDN/R _T	Shutdown/Timing Resistor	–0.3	0.8	SV_{IN}	–0.3	$SV_{IN} + 0.3$
2	SYNC/MODE	Mode Select/Synchronization Pin	0		SV_{IN}	–0.3	$SV_{IN} + 0.3$
3	SGND	Signal Ground		0			
4	SW	Switch Node	0		PV_{IN}	–0.3	$PV_{IN} + 0.3$
5	PGND	Main Power Ground		0			
6	PV _{IN}	Main Power Supply	–0.3		5.5	–0.3	$SV_{IN} + 0.3$
7	SV _{IN}	Signal Power Supply	2.5		5.5	–0.3	6
8	PGOOD	Power Good Pin	0		SV_{IN}	–0.3	6
9	V _{FB}	Output Feedback Pin	0	0.8	1.0	–0.3	$SV_{IN} + 0.3$
10	I _{TH}	Error Amplifier Compensation and Run Pin	0		1.5	–0.3	$SV_{IN} + 0.3$

3411i

TYPICAL PERFORMANCE CHARACTERISTICS

Burst Mode Operation

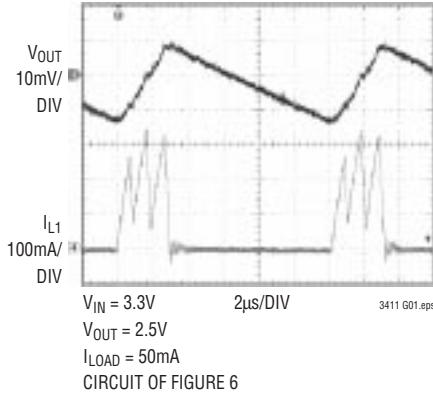

Pulse Skipping Mode

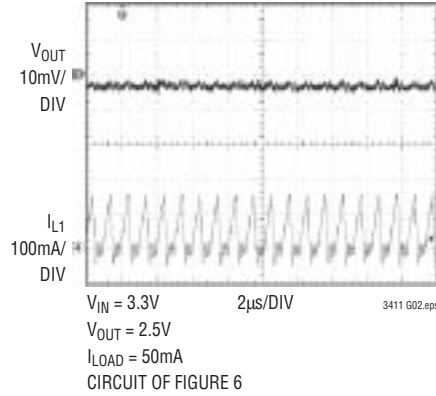

Forced Continuous Mode

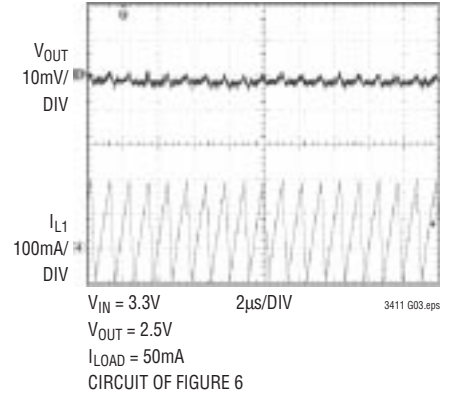

Efficiency vs Load Current

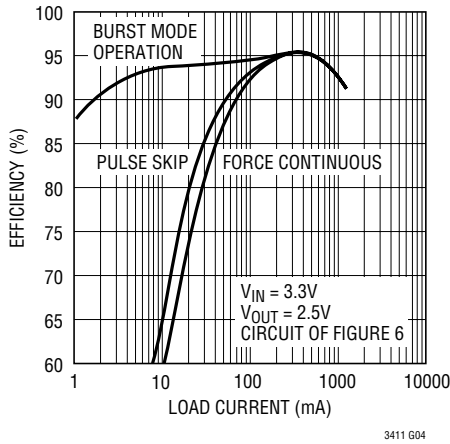

Efficiency vs V_{IN}

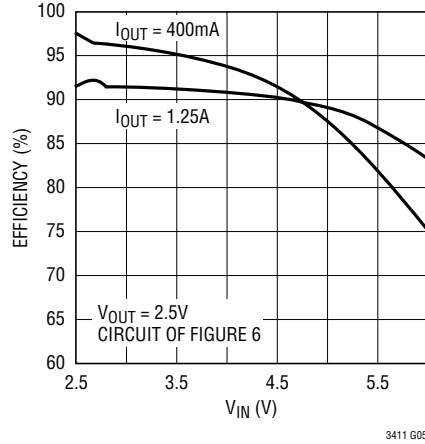

Load Step

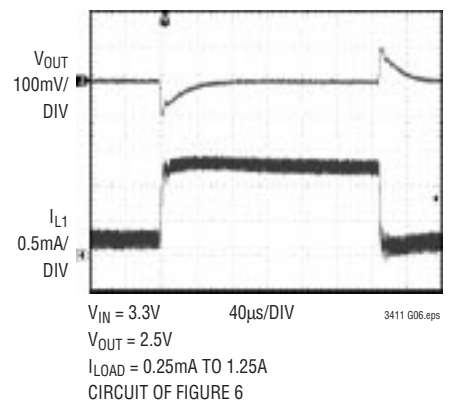

Load Regulation

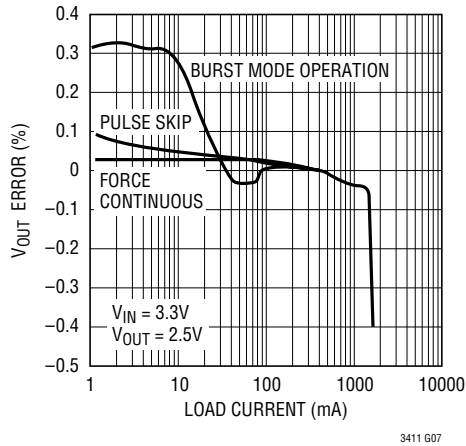

Line Regulation

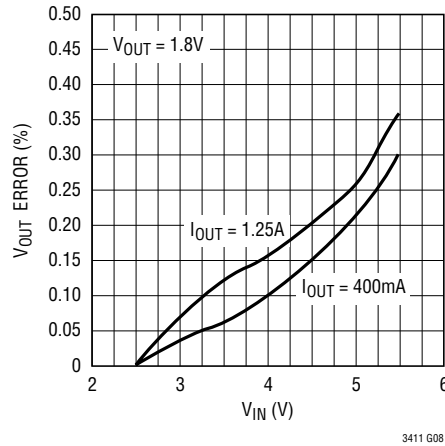

Frequency vs V_{IN}

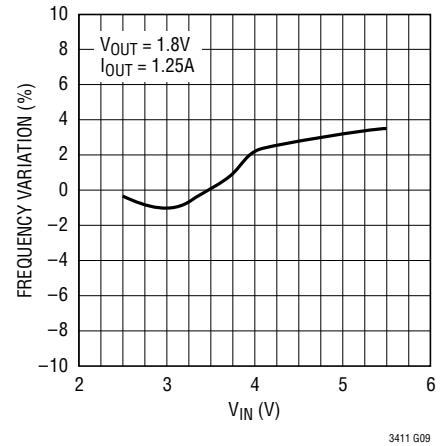

TYPICAL PERFORMANCE CHARACTERISTICS

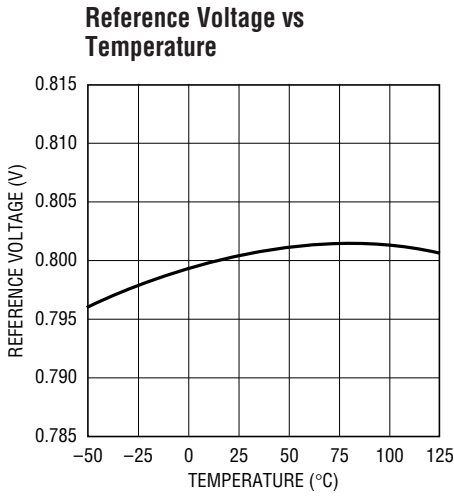

3411 G10

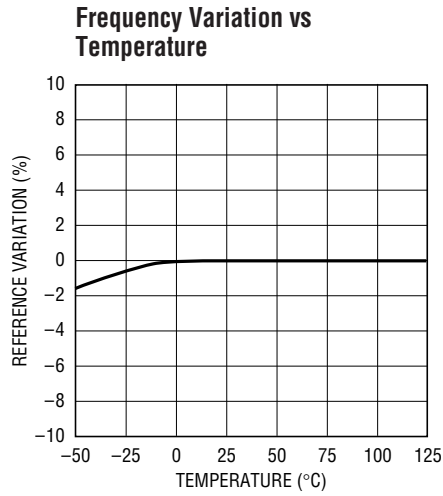

3411 G11

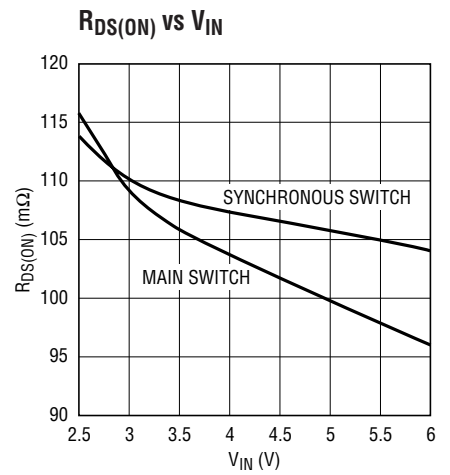

3411 G12

BLOCK DIAGRAM

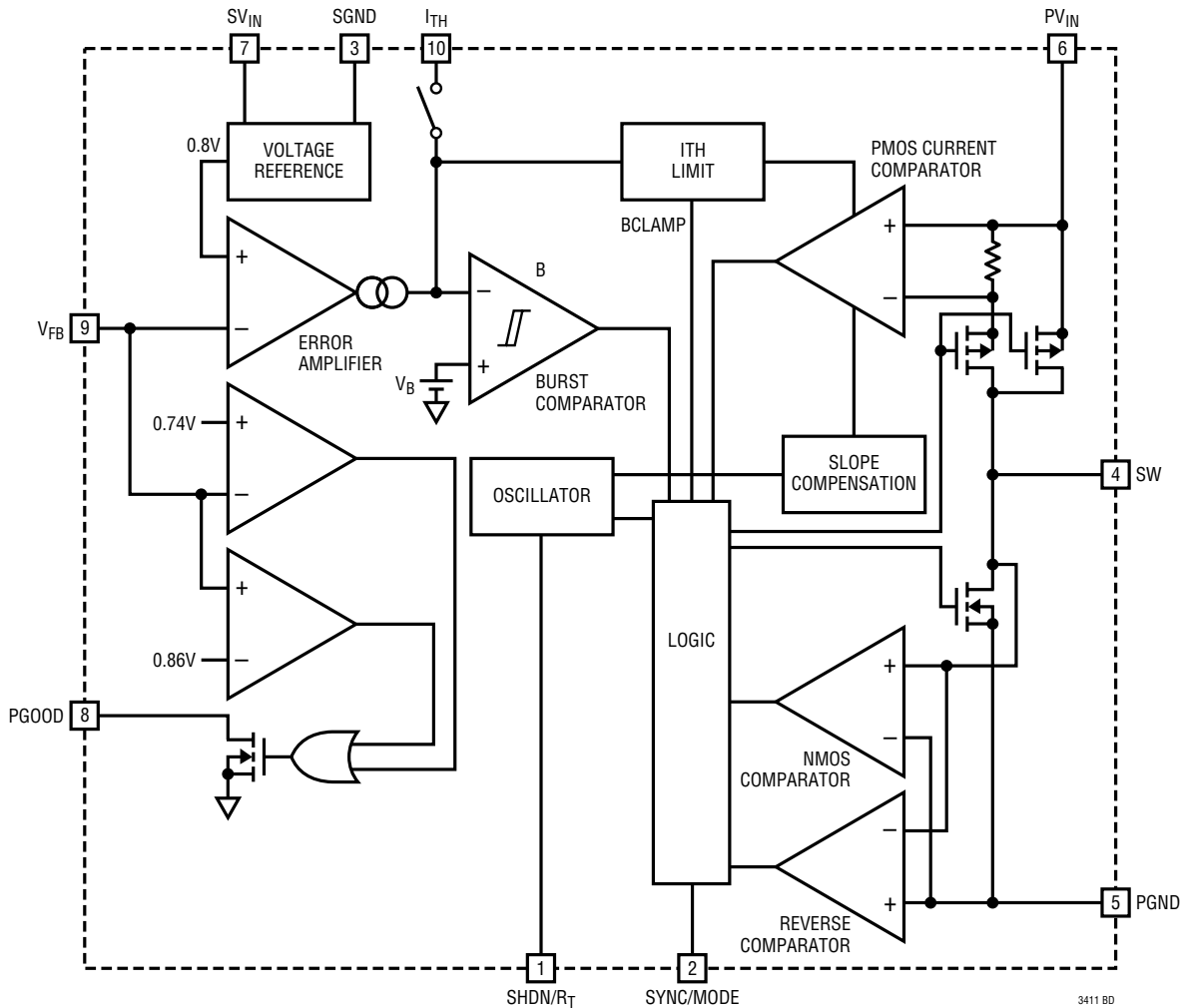

3411 BD

OPERATION

The LTC3411 uses a constant frequency, current mode architecture. The operating frequency is determined by the value of the R_T resistor or can be synchronized to an external oscillator. To suit a variety of applications, the selectable Mode pin, allows the user to trade-off noise for efficiency.

The output voltage is set by an external divider returned to the V_{FB} pin. An error amplifier compares the divided output voltage with a reference voltage of 0.8V and adjusts the peak inductor current accordingly. Overvoltage and undervoltage comparators will pull the PGOOD output low if the output voltage is not within $\pm 7.5\%$.

Main Control Loop

During normal operation, the top power switch (P-channel MOSFET) is turned on at the beginning of a clock cycle when the V_{FB} voltage is below the reference voltage. The current into the inductor and the load increases until the current limit is reached. The switch turns off and energy stored in the inductor flows through the bottom switch (N-channel MOSFET) into the load until the next clock cycle.

The peak inductor current is controlled by the voltage on the I_{TH} pin, which is the output of the error amplifier. This amplifier compares the V_{FB} pin to the 0.8V reference. When the load current increases, the V_{FB} voltage decreases slightly below the reference. This decrease causes the error amplifier to increase the I_{TH} voltage until the average inductor current matches the new load current.

The main control loop is shut down by pulling the SHDN/ R_T pin to SV_{IN} . A digital soft-start is enabled after shutdown, which will slowly ramp the peak inductor current up over 1024 clock cycles or until the output reaches regulation, whichever is first. Soft-start can be lengthened by ramping the voltage on the I_{TH} pin (see Applications Information section).

Low Current Operation

Three modes are available to control the operation of the LTC3411 at low currents. All three modes automatically switch from continuous operation to the selected mode when the load current is low.

To optimize efficiency, the Burst Mode operation can be selected. When the load is relatively light, the LTC3411 automatically switches into Burst Mode operation in which the PMOS switch operates intermittently based on load demand. By running cycles periodically, the switching losses which are dominated by the gate charge losses of the power MOSFETs are minimized. The main control loop is interrupted when the output voltage reaches the desired regulated value. The hysteretic voltage comparator B trips when I_{TH} is below 0.25V, shutting off the switch and reducing the power. The output capacitor and the inductor supply the power to the load until I_{TH}/RUN exceeds 0.31V, turning on the switch and the main control loop which starts another cycle.

For lower output voltage ripple at low currents, pulse skipping mode can be used. In this mode, the LTC3411 continues to switch at a constant frequency down to very low currents, where it will eventually begin skipping pulses.

Finally, in forced continuous mode, the inductor current is constantly cycled which creates a fixed output voltage ripple at all output current levels. This feature is desirable in telecommunications since the noise is at a constant frequency and is thus easy to filter out. Another advantage of this mode is that the regulator is capable of both sourcing current into a load and sinking some current from the output.

Dropout Operation

When the input supply voltage decreases toward the output voltage, the duty cycle increases to 100% which is the dropout condition. In dropout, the PMOS switch is turned on continuously with the output voltage being equal to the input voltage minus the voltage drops across the internal P-channel MOSFET and the inductor.

Low Supply Operation

The LTC3411 incorporates an undervoltage lockout circuit which shuts down the part when the input voltage drops below about 2.5V to prevent unstable operation.

APPLICATIONS INFORMATION

A general LTC3411 application circuit is shown in Figure 4. External component selection is driven by the load requirement, and begins with the selection of the inductor L1. Once L1 is chosen, C_{IN} and C_{OUT} can be selected.

Operating Frequency

Selection of the operating frequency is a tradeoff between efficiency and component size. High frequency operation allows the use of smaller inductor and capacitor values. Operation at lower frequencies improves efficiency by reducing internal gate charge losses but requires larger inductance values and/or capacitance to maintain low output ripple voltage.

The operating frequency, f_0 , of the LTC3411 is determined by an external resistor that is connected between the R_T pin and ground. The value of the resistor sets the ramp current that is used to charge and discharge an internal timing capacitor within the oscillator and can be calculated by using the following equation:

$$R_T = 9.78 \cdot 10^{11} (f_0)^{-1.08} (\Omega)$$

The maximum usable operating frequency is limited by the minimum on-time and the duty cycle. This can be calculated as:

$$f_{0(MAX)} \approx 6.67 \cdot (V_{OUT} / V_{IN(MAX)}) \text{ (MHz)}$$

Inductor Selection

Although the inductor does not influence the operating frequency, the inductor value has a direct effect on ripple current. The inductor ripple current ΔI_L decreases with higher inductance and increases with higher V_{IN} or V_{OUT} :

$$\Delta I_L = \frac{V_{OUT}}{f_0 \cdot L} \cdot \left(1 - \frac{V_{OUT}}{V_{IN}} \right)$$

Accepting larger values of ΔI_L allows the use of low inductances, but results in higher output voltage ripple, greater core losses, and lower output current capability.

A reasonable starting point for setting ripple current is $\Delta I_L = 0.3 \cdot I_{LIM}$, where I_{LIM} is the peak switch current limit. The largest ripple current ΔI_L occurs at the maximum

input voltage. To guarantee that the ripple current stays below a specified maximum, the inductor value should be chosen according to the following equation:

$$L = \frac{V_{OUT}}{f_0 \cdot \Delta I_L} \cdot \left(1 - \frac{V_{OUT}}{V_{IN(MAX)}} \right)$$

The inductor value will also have an effect on Burst Mode operation. The transition from low current operation begins when the peak inductor current falls below a level set by the burst clamp. Lower inductor values result in higher ripple current which causes this to occur at lower load currents. This causes a dip in efficiency in the upper range of low current operation. In Burst Mode operation, lower inductance values will cause the burst frequency to increase.

Inductor Core Selection

Different core materials and shapes will change the size/current and price/current relationship of an inductor. Toroid or shielded pot cores in ferrite or permalloy materials are small and don't radiate much energy, but generally cost more than powdered iron core inductors with similar electrical characteristics. The choice of which style inductor to use often depends more on the price vs size requirements and any radiated field/EMI requirements than on what the LTC3411 requires to operate. Table 1 shows some typical surface mount inductors that work well in LTC3411 applications.

Table 1. Representative Surface Mount Inductors

MANUFACTURER	PART NUMBER	VALUE	MAX DC CURRENT	DCR	HEIGHT
Toko	A914BYW-2R2M-D52LC	2.2 μ H	2.05A	49mW	2mm
Toko	A915AY-2ROM-D53LC	2 μ H	3.3A	22mW	3mm
Coilcraft	D01608C-222	2.2 μ H	2.3A	70mW	3mm
Coilcraft	LP01704-222M	2.2 μ H	2.4A	120mW	1mm
Sumida	CDRH4D282R2	2.2 μ H	2.04A	23mW	3mm
Sumida	CDC5D232R2	2.2 μ H	2.16A	30mW	2.5mm
Taiyo Yuden	N06DB2R2M	2.2 μ H	3.2A	29mW	3.2mm
Taiyo Yuden	N05DB2R2M	2.2 μ H	2.9A	32mW	2.8mm
Murata	LQN6C2R2M04	2.2 μ H	3.2A	24mW	5mm

APPLICATIONS INFORMATION

Catch Diode Selection

Although unnecessary in most applications, a small improvement in efficiency can be obtained in a few applications by including the optional diode D1 shown in Figure 4, which conducts when the synchronous switch is off. When using Burst Mode operation or pulse skip mode, the synchronous switch is turned off at a low current and the remaining current will be carried by the optional diode. It is important to adequately specify the diode peak current and average power dissipation so as not to exceed the diode ratings. Unfortunately, one problem that a Schottky diode can introduce is higher leakage current at high temperatures, which could reduce the low current efficiency. Some LTC3411 circuits can be improved by using a Schottky, such as an MBR0520L.

Remember to keep lead lengths short and observe proper grounding (see Board Layout Considerations) to avoid ringing and increased dissipation.

Input Capacitor (C_{IN}) Selection

In continuous mode, the input current of the converter is a square wave with a duty cycle of approximately V_{OUT}/V_{IN} . To prevent large voltage transients, a low equivalent series resistance (ESR) input capacitor sized for the maximum RMS current must be used. The maximum RMS capacitor current is given by:

$$I_{RMS} \approx I_{MAX} \frac{\sqrt{V_{OUT}(V_{IN} - V_{OUT})}}{V_{IN}}$$

where the maximum average output current I_{MAX} equals the peak current minus half the peak-to-peak ripple current, $I_{MAX} = I_{LIM} - \Delta I_L/2$.

This formula has a maximum at $V_{IN} = 2V_{OUT}$, where $I_{RMS} = I_{OUT}/2$. This simple worst case is commonly used to design because even significant deviations do not offer much relief. Note that capacitor manufacturer's ripple current ratings are often based on only 2000 hours lifetime. This makes it advisable to further derate the capacitor, or choose a capacitor rated at a higher temperature

than required. Several capacitors may also be paralleled to meet the size or height requirements of the design. An additional 0.1 μ F to 1 μ F ceramic capacitor is also recommended on V_{IN} for high frequency decoupling, when not using an all ceramic capacitor solution.

Output Capacitor (C_{OUT}) Selection

The selection of C_{OUT} is driven by the required ESR to minimize voltage ripple and load step transients. Typically, once the ESR requirement is satisfied, the capacitance is adequate for filtering. The output ripple (ΔV_{OUT}) is determined by:

$$\Delta V_{OUT} \approx \Delta I_L \left(ESR + \frac{1}{8f_0 C_{OUT}} \right)$$

where f = operating frequency, C_{OUT} = output capacitance and ΔI_L = ripple current in the inductor. The output ripple is highest at maximum input voltage since ΔI_L increases with input voltage. With $\Delta I_L = 0.3 \cdot I_{LIM}$ the output ripple will be less than 100mV at maximum V_{IN} and $f_0 = 1$ MHz with:

$$ESR_{C_{OUT}} < 150m\Omega$$

Once the ESR requirements for C_{OUT} have been met, the RMS current rating generally far exceeds the $I_{RIPPLE(P-P)}$ requirement, except for an all ceramic solution.

In surface mount applications, multiple capacitors may have to be paralleled to meet the capacitance, ESR or RMS current handling requirement of the application. Aluminum electrolytic, special polymer, ceramic and dry tantalum capacitors are all available in surface mount packages. The OS-CON semiconductor dielectric capacitor available from Sanyo has the lowest ESR(size) product of any aluminum electrolytic at a somewhat higher price. Special polymer capacitors, such as Sanyo POSCAP, offer very low ESR, but have a lower capacitance density than other types. Tantalum capacitors have the highest capacitance density, but it has a larger ESR and it is critical that the capacitors are surge tested for use in switching power supplies. An

APPLICATIONS INFORMATION

excellent choice is the AVX TPS series of surface mount tantalums, available in case heights ranging from 2mm to 4mm. Aluminum electrolytic capacitors have a significantly larger ESR, and is often used in extremely cost-sensitive applications provided that consideration is given to ripple current ratings and long term reliability. Ceramic capacitors have the lowest ESR and cost but also have the lowest capacitance density, a high voltage and temperature coefficient and exhibit audible piezoelectric effects. In addition, the high Q of ceramic capacitors along with trace inductance can lead to significant ringing. Other capacitor types include the Panasonic specialty polymer (SP) capacitors.

In most cases, 0.1 μ F to 1 μ F of ceramic capacitors should also be placed close to the LTC3411 in parallel with the main capacitors for high frequency decoupling.

Ceramic Input and Output Capacitors

Higher value, lower cost ceramic capacitors are now becoming available in smaller case sizes. These are tempting for switching regulator use because of their very low ESR. Unfortunately, the ESR is so low that it can cause loop stability problems. Solid tantalum capacitor ESR generates a loop “zero” at 5kHz to 50kHz that is instrumental in giving acceptable loop phase margin. Ceramic capacitors remain capacitive to beyond 300kHz and usually resonate with their ESL before ESR becomes effective. Also, ceramic caps are prone to temperature effects which requires the designer to check loop stability over the operating temperature range. To minimize their large temperature and voltage coefficients, only X5R or X7R ceramic capacitors should be used. A good selection of ceramic capacitors is available from Taiyo Yuden, TDK and Murata.

Great care must be taken when using only ceramic input and output capacitors. When a ceramic capacitor is used at the input and the power is being supplied through long wires, such as from a wall adapter, a load step at the output can induce ringing at the V_{IN} pin. At best, this ringing can couple to the output and be mistaken as loop instability. At worst, the ringing at the input can be large enough to damage the part.

Since the ESR of a ceramic capacitor is so low, the input and output capacitor must instead fulfill a charge storage requirement. During a load step, the output capacitor must instantaneously supply the current to support the load until the feedback loop raises the switch current enough to support the load. The time required for the feedback loop to respond is dependent on the compensation components and the output capacitor size. Typically, 3 to 4 cycles are required to respond to a load step, but only in the first cycle does the output drop linearly. The output droop, V_{DROOP} , is usually about 2 to 3 times the linear drop of the first cycle. Thus, a good place to start is with the output capacitor size of approximately:

$$C_{OUT} \approx 2.5 \frac{\Delta I_{OUT}}{f_o \cdot V_{DROOP}}$$

More capacitance may be required depending on the duty cycle and load step requirements.

In most applications, the input capacitor is merely required to supply high frequency bypassing, since the impedance to the supply is very low. A 10 μ F ceramic capacitor is usually enough for these conditions.

Setting the Output Voltage

The LTC3411 develops a 0.8V reference voltage between the feedback pin, V_{FB} , and the signal ground as shown in Figure 4. The output voltage is set by a resistive divider according to the following formula:

$$V_{OUT} \approx 0.8V \left(1 + \frac{R2}{R1} \right)$$

Keeping the current small (<5 μ A) in these resistors maximizes efficiency, but making them too small may allow stray capacitance to cause noise problems and reduce the phase margin of the error amp loop.

To improve the frequency response, a feed-forward capacitor C_F may also be used. Great care should be taken to route the V_{FB} line away from noise sources, such as the inductor or the SW line.

APPLICATIONS INFORMATION

Shutdown and Soft-Start

The SHDN/R_T pin is a dual purpose pin that sets the oscillator frequency and provides a means to shut down the LTC3411. This pin can be interfaced with control logic in several ways, as shown in Figure 2(a) and Figure 2(b).

The I_{TH} pin is primarily for loop compensation, but it can also be used to increase the soft-start time. Soft start reduces surge currents from V_{IN} by gradually increasing the internal peak inductor current. Power supply sequencing can also be accomplished using this pin. The LTC3411 has an internal digital soft-start which steps up a clamp on I_{TH} over 1024 clock cycles, as can be seen in Figure 3.

The soft-start time can be increased by ramping the voltage on I_{TH} during start-up as shown in Figure 2(c). As the voltage on I_{TH} ramps through its operating range the internal peak current limit is also ramped at a proportional linear rate.

Mode Selection and Frequency Synchronization

The SYNC/MODE pin is a multipurpose pin which provides mode selection and frequency synchronization. Connecting this pin to V_{IN} enables Burst Mode Operation, which provides the best low current efficiency at the cost of a higher output voltage ripple. When this pin is connected to

ground, pulse skipping operation is selected which provides the lowest output voltage and current ripple at the cost of low current efficiency. Applying a voltage within 1V of the supplies, results in forced continuous mode, which creates a fixed output ripple and is capable of sinking some current (about 1/2ΔI_L). Since the switching noise is constant in this mode, it is also the easiest to filter out. In many cases, the output voltage can be simply connected to the SYNC/MODE pin, giving the forced continuous mode, except at startup.

The LTC3411 can also be synchronized to an external clock signal by the SYNC/MODE pin. The internal oscillator frequency should be set to 20% lower than the external clock frequency to ensure adequate slope compensation, since slope compensation is derived from the internal oscillator. During synchronization, the mode is set to pulse skipping and the top switch turn on is synchronized to the rising edge of the external clock.

Checking Transient Response

The OPTI-LOOP compensation allows the transient response to be optimized for a wide range of loads and output capacitors. The availability of the I_{TH} pin not only allows optimization of the control loop behavior but also

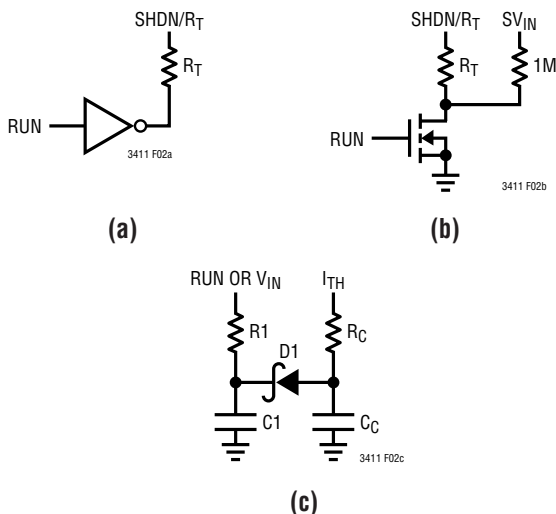

Figure 2. SHDN/R_T Pin Interfacing and External Soft-Start

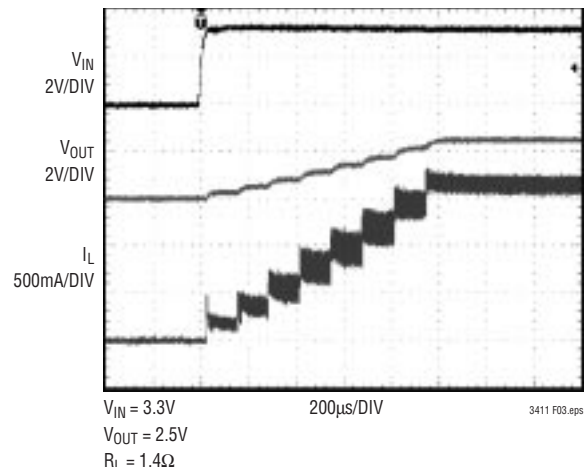

Figure 3. Digital Soft-Start

APPLICATIONS INFORMATION

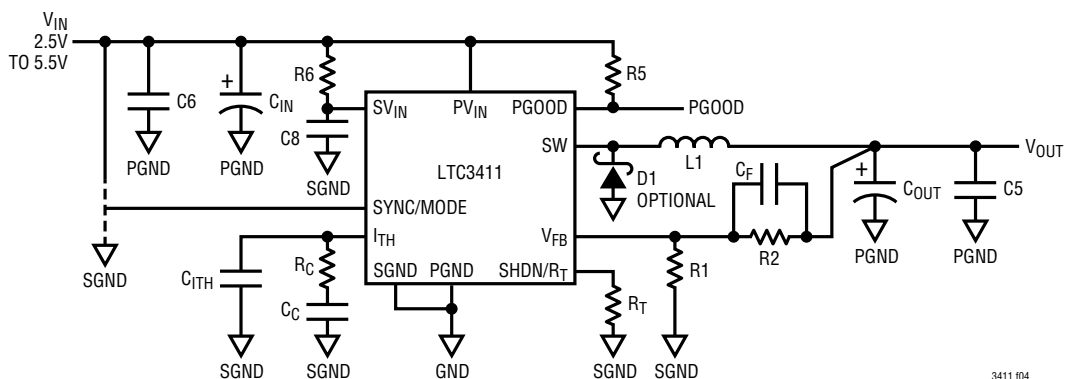

Figure 4. LTC3411 General Schematic

provides a DC coupled and AC filtered closed loop response test point. The DC step, rise time and settling at this test point truly reflects the closed loop response. Assuming a predominantly second order system, phase margin and/or damping factor can be estimated using the percentage of overshoot seen at this pin. The bandwidth can also be estimated by examining the rise time at the pin.

The I_{TH} external components shown in the Figure 1 circuit will provide an adequate starting point for most applications. The series R-C filter sets the dominant pole-zero loop compensation. The values can be modified slightly (from 0.5 to 2 times their suggested values) to optimize transient response once the final PC layout is done and the particular output capacitor type and value have been determined. The output capacitors need to be selected because the various types and values determine the loop feedback factor gain and phase. An output current pulse of 20% to 100% of full load current having a rise time of $1\mu\text{s}$ to $10\mu\text{s}$ will produce output voltage and I_{TH} pin waveforms that will give a sense of the overall loop stability without breaking the feedback loop.

Switching regulators take several cycles to respond to a step in load current. When a load step occurs, V_{OUT} immediately shifts by an amount equal to $\Delta I_{LOAD} \cdot \text{ESR}$, where ESR is the effective series resistance of C_{OUT} . ΔI_{LOAD} also begins to charge or discharge C_{OUT} generating a feedback error signal used by the regulator to return V_{OUT} to its steady-state value. During this recovery time, V_{OUT} can be monitored for overshoot or ringing that would indicate a stability problem.

The initial output voltage step may not be within the bandwidth of the feedback loop, so the standard second order overshoot/DC ratio cannot be used to determine phase margin. The gain of the loop increases with R and the bandwidth of the loop increases with decreasing C. If R is increased by the same factor that C is decreased, the zero frequency will be kept the same, thereby keeping the phase the same in the most critical frequency range of the feedback loop. In addition, a feedforward capacitor C_F can be added to improve the high frequency response, as shown in Figure 4. Capacitor C_F provides phase lead by creating a high frequency zero with R2 which improves the phase margin.

The output voltage settling behavior is related to the stability of the closed-loop system and will demonstrate the actual overall supply performance. For a detailed explanation of optimizing the compensation components, including a review of control loop theory, refer to Linear Technology Application Note 76.

In some applications, a more severe transient can be caused by switching in loads with large ($>1\mu\text{F}$) input capacitors. The discharged input capacitors are effectively put in parallel with C_{OUT} , causing a rapid drop in V_{OUT} . No regulator can deliver enough current to prevent this problem, if the switch connecting the load has low resistance and is driven quickly. The solution is to limit the turn-on speed of the load switch driver. A hot swap controller is designed specifically for this purpose and usually incorporates current limiting, short-circuit protection, and soft-starting.

APPLICATIONS INFORMATION

Efficiency Considerations

The percent efficiency of a switching regulator is equal to the output power divided by the input power times 100%. It is often useful to analyze individual losses to determine what is limiting the efficiency and which change would produce the most improvement. Percent efficiency can be expressed as:

$$\% \text{Efficiency} = 100\% - (L1 + L2 + L3 + \dots)$$

where L1, L2, etc. are the individual losses as a percentage of input power.

Although all dissipative elements in the circuit produce losses, four main sources usually account for most of the losses in LTC3411 circuits: 1) LTC3411 V_{IN} current, 2) switching losses, 3) I^2R losses, 4) other losses.

1) The V_{IN} current is the DC supply current given in the electrical characteristics which excludes MOSFET driver and control currents. V_{IN} current results in a small (<0.1%) loss that increases with V_{IN} , even at no load.

2) The switching current is the sum of the MOSFET driver and control currents. The MOSFET driver current results from switching the gate capacitance of the power MOSFETs. Each time a MOSFET gate is switched from low to high to low again, a packet of charge dQ moves from V_{IN} to ground. The resulting dQ/dt is a current out of V_{IN} that is typically much larger than the DC bias current. In continuous mode, $I_{GATECHG} = f_0(QT + QB)$, where QT and QB are the gate charges of the internal top and bottom MOSFET switches. The gate charge losses are proportional to V_{IN} and thus their effects will be more pronounced at higher supply voltages.

3) I^2R Losses are calculated from the DC resistances of the internal switches, R_{SW} , and external inductor, R_L . In continuous mode, the average output current flowing through inductor L but is “chopped” between the internal top and bottom switches. Thus, the series resistance looking into the SW pin is a function of both top and bottom MOSFET $R_{DS(ON)}$ and the duty cycle (DC) as follows:

$$R_{SW} = (R_{DS(ON)TOP})(DC) + (R_{DS(ON)BOT})(1 - DC)$$

The $R_{DS(ON)}$ for both the top and bottom MOSFETs can be obtained from the Typical Performance Characteristics curves. Thus, to obtain I^2R losses:

$$I^2R \text{ losses} = I_{OUT}^2(R_{SW} + R_L)$$

4) Other “hidden” losses such as copper trace and internal battery resistances can account for additional efficiency degradations in portable systems. It is very important to include these “system” level losses in the design of a system. The internal battery and fuse resistance losses can be minimized by making sure that C_{IN} has adequate charge storage and very low ESR at the switching frequency. Other losses including diode conduction losses during dead-time and inductor core losses generally account for less than 2% total additional loss.

Thermal Considerations

In a majority of applications, the LTC3411 does not dissipate much heat due to its high efficiency. However, in applications where the LTC3411 is running at high ambient temperature with low supply voltage and high duty cycles, such as in dropout, the heat dissipated may exceed the maximum junction temperature of the part. If the junction temperature reaches approximately 150°C, both power switches will be turned off and the SW node will become high impedance.

To avoid the LTC3411 from exceeding the maximum junction temperature, the user will need to do some thermal analysis. The goal of the thermal analysis is to determine whether the power dissipated exceeds the maximum junction temperature of the part. The temperature rise is given by:

$$T_{RISE} = P_D \cdot \theta_{JA}$$

where P_D is the power dissipated by the regulator and θ_{JA} is the thermal resistance from the junction of the die to the ambient temperature.

The junction temperature, T_J , is given by:

$$T_J = T_{RISE} + T_{AMBIENT}$$

As an example, consider the case when the LTC3411 is in dropout at an input voltage of 3.3V with a load current of 1A. From the Typical Performance Characteristics graph of Switch Resistance, the $R_{DS(ON)}$ resistance of the

APPLICATIONS INFORMATION

P-channel switch is 0.11Ω . Therefore, power dissipated by the part is:

$$P_D = I^2 \cdot R_{DS(ON)} = 110\text{mW}$$

The MS10 package junction-to-ambient thermal resistance, θ_{JA} , will be in the range of 100°C/W to 120°C/W . Therefore, the junction temperature of the regulator operating in a 70°C ambient temperature is approximately:

$$T_J = 0.12 \cdot 120 + 70 = 83.2^\circ\text{C}$$

Remembering that the above junction temperature is obtained from an $R_{DS(ON)}$ at 25°C , we might recalculate the junction temperature based on a higher $R_{DS(ON)}$ since it increases with temperature. However, we can safely assume that the actual junction temperature will not exceed the absolute maximum junction temperature of 125°C .

Design Example

As a design example, consider using the LTC3411 in a portable application with a Li-Ion battery. The battery provides a $V_{IN} = 2.5\text{V}$ to 4.2V . The load requires a maximum of 1A in active mode and 10mA in standby mode. The output voltage is $V_{OUT} = 2.5\text{V}$. Since the load still needs power in standby, Burst Mode operation is selected for good low load efficiency.

First, calculate the timing resistor:

$$R_T = 9.78 \cdot 10^{11} (1\text{MHz})^{-1.08} = 323.8\text{k}$$

Use a standard value of 324k . Next, calculate the inductor value for about 30% ripple current at maximum V_{IN} :

$$L = \frac{2.5\text{V}}{1\text{MHz} \cdot 510\text{mA}} \cdot \left(1 - \frac{2.5\text{V}}{4.2\text{V}}\right) = 2\mu\text{H}$$

Choosing the closest inductor from a vendor of $2.2\mu\text{H}$, results in a maximum ripple current of:

$$\Delta I_L = \frac{2.5\text{V}}{1\text{MHz} \cdot 2.2\mu\text{H}} \cdot \left(1 - \frac{2.5\text{V}}{4.2\text{V}}\right) = 460\text{mA}$$

For cost reasons, a ceramic capacitor will be used. C_{OUT} selection is then based on load step droop instead of ESR requirements. For a 5% output droop:

$$C_{OUT} \approx 2.5 \frac{1\text{A}}{1\text{MHz} \cdot (5\% \cdot 2.5\text{V})} = 20\mu\text{F}$$

The closest standard value is $22\mu\text{F}$. Since the output impedance of a Li-Ion battery is very low, C_{IN} is typically $10\mu\text{F}$. In noisy environments, decoupling SV_{IN} from PV_{IN} with an R6/C8 filter of $1\Omega/0.1\mu\text{F}$ may help, but is typically not needed.

The output voltage can now be programmed by choosing the values of $R1$ and $R2$. To maintain high efficiency, the current in these resistors should be kept small. Choosing $2\mu\text{A}$ with the 0.8V feedback voltage makes $R1 \sim 400\text{k}$. A close standard 1% resistor is 412k and $R2$ is then 887k .

The compensation should be optimized for these components by examining the load step response but a good place to start for the LTC3411 is with a $13\text{k}\Omega$ and 1000pF filter. The output capacitor may need to be increased depending on the actual undershoot during a load step.

The PGOOD pin is a common drain output and requires a pull-up resistor. A 100k resistor is used for adequate speed.

Figure 1 shows the complete schematic for this design example.

Board Layout Considerations

When laying out the printed circuit board, the following checklist should be used to ensure proper operation of the LTC3411. These items are also illustrated graphically in the layout diagram of Figure 5. Check the following in your layout:

1. Does the capacitor C_{IN} connect to the power V_{IN} (Pin 6) and power GND (Pin 5) as close as possible? This capacitor provides the AC current to the internal power MOSFETs and their drivers.
2. Are the C_{OUT} and L1 closely connected? The (-) plate of C_{OUT} returns current to PGND and the (-) plate of C_{IN} .

APPLICATIONS INFORMATION

- The resistor divider, R1 and R2, must be connected between the (+) plate of C_{OUT} and a ground line terminated near SGND (Pin 3). The feedback signal V_{FB} should be routed away from noisy components and traces, such as the SW line (Pin 4), and its trace should be minimized.
- Keep sensitive components away from the SW pin. The input capacitor C_{IN}, the compensation capacitor C_C and C_{ITH} and all the resistors R1, R2, R_T, and R_C should be routed away from the SW trace and the inductor L1.

- A ground plane is preferred, but if not available, keep the signal and power grounds segregated with small signal components returning to the SGND pin at one point which is then connected to the PGND pin.
- Flood all unused areas on all layers with copper. Flooding with copper will reduce the temperature rise of power components. These copper areas should be connected to one of the input supplies: PV_{IN}, PGND, SV_{IN} or SGND.

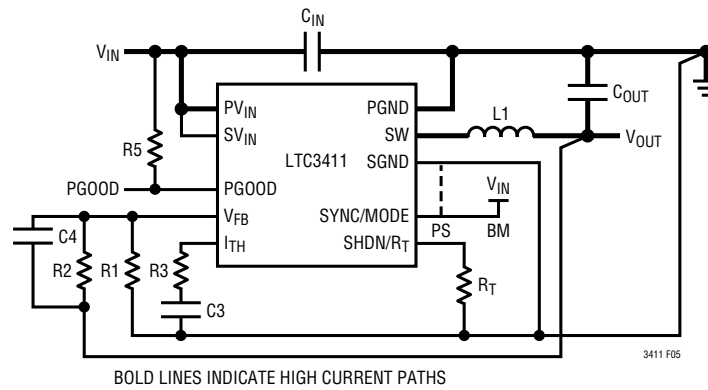
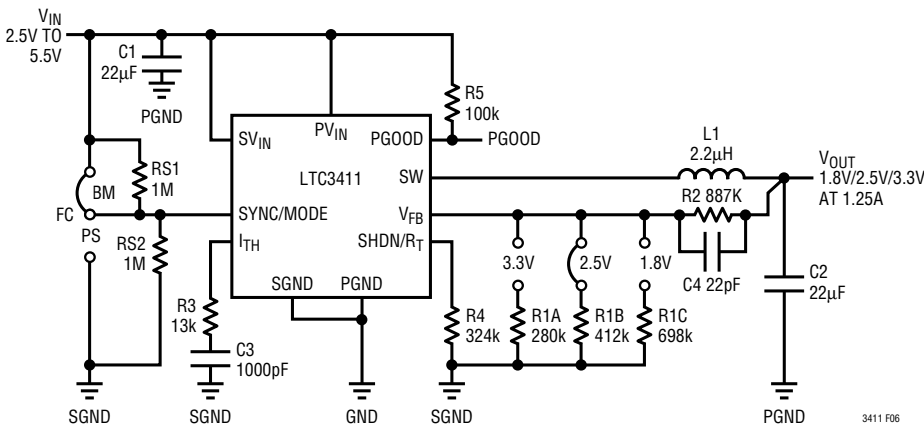

Figure 5. LTC3411 Layout Diagram (See Board Layout Checklist)

TYPICAL APPLICATIONS



C1, C2: TAIYO YUDEN JMK325BJ226MM
L1: TOKO A914BYW-2R2M (D52LC SERIES)

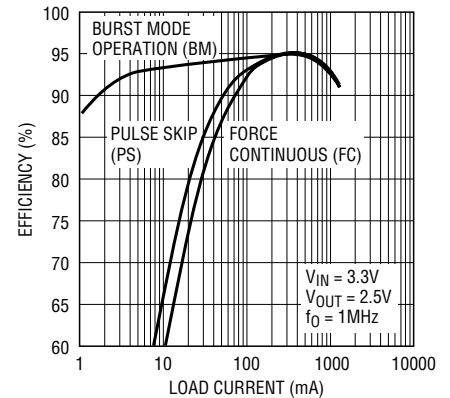
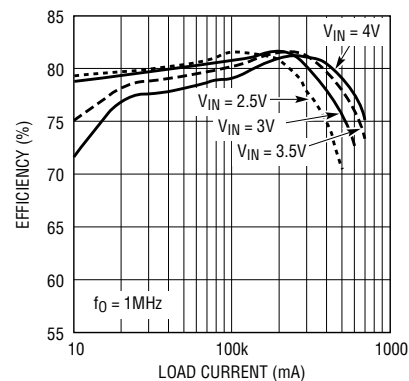
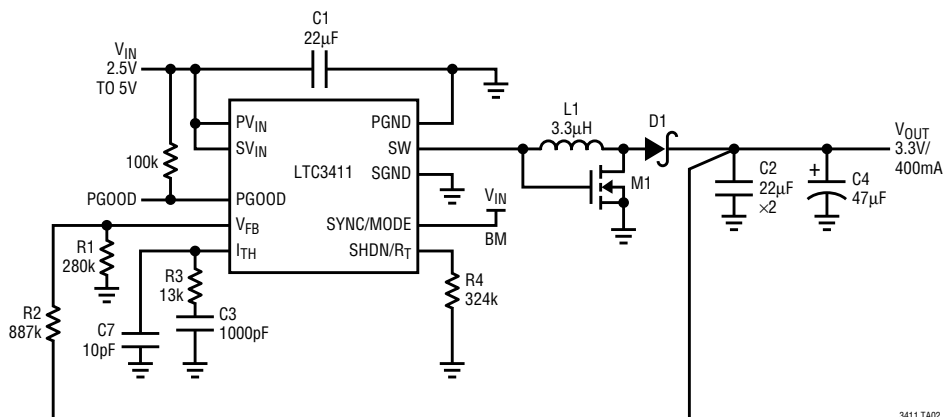

Figure 6. General Purpose Buck Regulator Using Ceramic Capacitors

TYPICAL APPLICATIONS

Single Inductor, Positive, Buck-Boost Converter



- C1, C2: TAIYO YUDEN JMK325BJ226MM
 C3: SANYO POSCAP 6TPA47M
 C4: ON MBRM120L
 L1: TOKO A915AY-3R3M (D53LC SERIES)
 M1: SILICONIX Si2302DS

3411 TA02

3411 TA03

PACKAGE DESCRIPTION

MS10 Package 10-Lead Plastic MSOP (Reference LTC DWG # 05-08-1661)

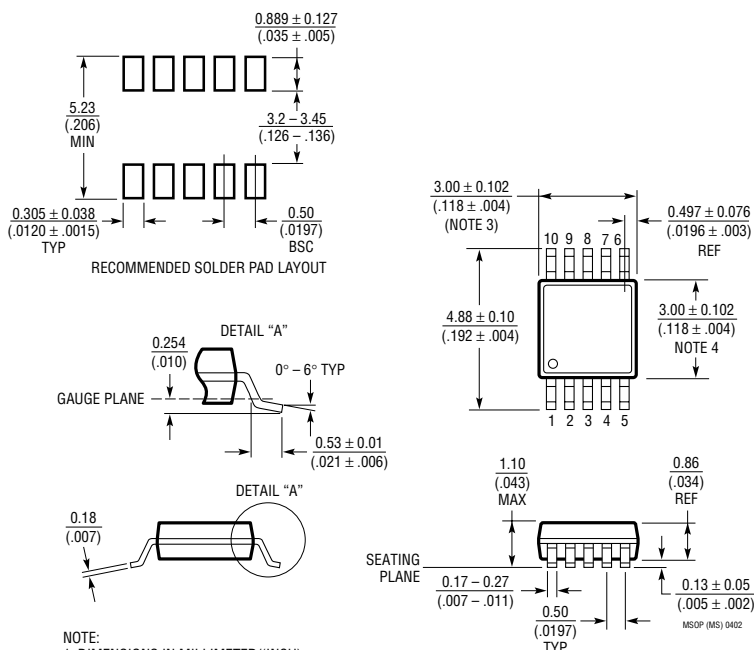

- NOTE:
1. DIMENSIONS IN MILLIMETER/(INCH)
 2. DRAWING NOT TO SCALE
 3. DIMENSION DOES NOT INCLUDE MOLD FLASH, PROTRUSIONS OR GATE BURRS.
MOLD FLASH, PROTRUSIONS OR GATE BURRS SHALL NOT EXCEED 0.152mm (.006") PER SIDE
 4. DIMENSION DOES NOT INCLUDE INTERLEAD FLASH OR PROTRUSIONS.
INTERLEAD FLASH OR PROTRUSIONS SHALL NOT EXCEED 0.152mm (.006") PER SIDE
 5. LEAD COPLANARITY (BOTTOM OF LEADS AFTER FORMING) SHALL BE 0.102mm (.004") MAX

3411i

TYPICAL APPLICATION

2mm Height, 2MHz, Li-Ion to 1.8V Converter

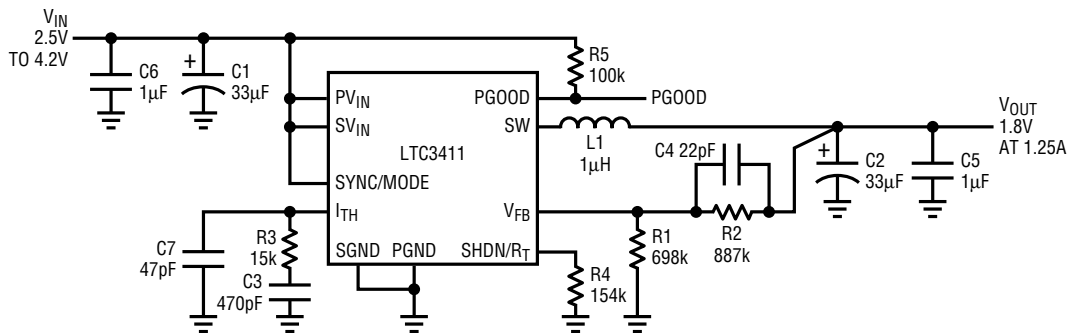

C1, C2: AVX TPSB336K006R0600
 C4, C5: TAIYO YUDEN LMK212BJ105MG
 L1: COILCRAFT DO1606T-102

3411 TA04

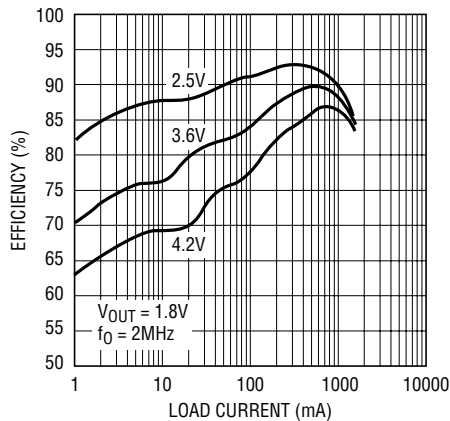

3411 TA05

RELATED PARTS

PART NUMBER	DESCRIPTION	COMMENTS
LTC1174/LTC1174-3.3	High Efficiency Step-Down and Inverting DC/DC Converter	Monolithic Switching Regulator, Burst Mode Operation
LTC1265	1.2A, High Efficiency Step-Down DC/DC Converter	Constant Off-Time Monolithic, Burst Mode Operation
LT1375/LT1376	1.5A, 500kHz Step-Down Switching Regulator	High Frequency, Small Inductor, High Efficiency
LTC1474/LTC1475	Monolithic High Efficiency Step-Down Regulator	10µA I _Q , Up to 250mA, 8-Pin MSOP-8 and SO-8 Packages
LTC1701/LTC1701B	Monolithic Current Mode Step-Down Regulator	1MHz, Up to 500mA, ThinSOT™ Package
LT1707	Monolithic Synchronous Step-Down Regulator	350kHz, 200µA I _Q , Up to 600mA, SO-8 Package
LT1765	Monolithic Step-Down Regulator	1.25MHz, Up to 2.5A, SO-8, TSSOP-16E, 3V < V _{IN} < 25V
LT1767	Monolithic Step-Down Regulator	1.25MHz, Up to 1.2A, MSOP-8, 3V < V _{IN} < 25V
LTC1875	Monolithic Synchronous Step-Down Regulator	550kHz, 15µA I _Q , Up to 1.5A, TSSOP-16 Package
LTC3404	Monolithic Synchronous Step-Down Regulator	1.4MHz, 10µA I _Q , Up to 600mA, MSOP-8, V _{IN} < 6V
LTC3405/LTC3405A	Monolithic Synchronous Step-Down Regulators	1.5MHz, 25µA I _Q , Up to 300mA, ThinSOT Package

ThinSOT is a trademark of Linear Technology Corporation.

3411i