

SOLID TANTALUM CHIP CAPACITORS

	PAGE
GENERAL PERFORMANCE CHARACTERISTICS.....	4-14
T491 SERIES — INDUSTRIAL GRADE	15-18
T492 SERIES — CWR11 STYLE PER MIL-PRF-55365/8.....	19-20
T494 SERIES — LOW ESR, INDUSTRIAL GRADE	21-23
T495 SERIES — LOW ESR, SURGE ROBUST	24-26
T496 SERIES — FAIL-SAFE WITH BUILT-IN FUSE	27-28
T510 SERIES — ULTRA-LOW ESR	29-31

POLYMER TANTALUM CHIP CAPACITORS

	PAGE
GENERAL PERFORMANCE CHARACTERISTICS.....	32-37
T520 SERIES — KO-CAP POLYMER	38-39
T530 SERIES — KO-CAP POLYMER - MULTIPLE ANODE.....	40-41

CERAMIC CHIP CAPACITORS

	PAGE
GENERAL PERFORMANCE CHARACTERISTICS.....	42-46
CERAMIC CHIP-STANDARD	47-51
LAND DIMENSIONS	51
THICKNESS CODE REFERENCE CHART.....	52
CERAMIC CAPACITOR ARRAY	53-54
MIL-PRF-55681 ESTABLISHED RELIABILITY	55-59
MIL-PRF-55681 TAPE AND REEL QUANTITIES	59

Mil-PRF-123 and GR900 high-reliability ceramic chips are also available. Refer to KEMET Catalog F-3054 for detailed information.

TANTALUM & CERAMIC CHIP PACKAGING

	PAGE
TANTALUM CHIP PACKAGING INFORMATION.....	60
CERAMIC CHIP PACKAGING INFORMATION	61
EMBOSSED CARRIER TAPE REELING INFORMATION	62-63
PUNCHED CARRIER TAPE (PAPER TAPE) REELING INFORMATION	64
BULK CASSETTE PACKAGING	65
CERAMIC CHIP MARKING.....	65

NOTICE

Although the information in this catalog has been carefully checked for accuracy, and is believed to be correct and current, no warranty, either express or implied, is made as to either its applicability to, or its compatibility with, specific requirements; nor does KEMET Electronics Corporation assume any responsibility for correctness of this information, nor for damages consequent to its use. All design characteristics, specifications, tolerances, and the like are subject to change without notice.

NOTICE

Any capacitor misapplied may fail and there by damage other circuit components. Please refer to application notes and recommendations in this catalog for a complete description of capacitor characteristics.



ISO 9001 Registration
The quality management system for manufacture of solid tantalum chips for surface mount applications has satisfied the requirements of ISO 9001.



ISO 9001 Registration
The quality management system for the manufacture of ceramic chips for surface mount applications has satisfied the requirements of ISO 9001.

INTRODUCTION

Ceramic chips consist of formulated ceramic dielectric materials which have been fabricated into thin layers, interspersed with metal electrodes alternately exposed on opposite edges of the laminated structure. The entire structure is then fired at high temperature to produce a monolithic block which provides high capacitance values in a small physical volume. After firing, conductive terminations are applied to opposite ends of the chip to make contact with the exposed electrodes. Standard end terminations use a nickel barrier layer and a tin overplate to provide excellent solderability for the customer.

KEMET multilayer ceramic chip capacitors are produced in plants designed specifically for chip capacitor manufacture. The process features a high degree of mechanization as well as precise controls over raw materials and process conditions. Manufacturing is supplemented by extensive Technology, Engineering and Quality Assurance programs.

KEMET ceramic chip capacitors are offered in the five most popular temperature characteristics. These are designated by the Electronics Industries Association (EIA) as the ultra-stable C0G (also known as NP0, military version BP), the stable X7R (military BX or BR), the stable X5R, and the general purpose Z5U and Y5V. A wide range of sizes are available. KEMET multilayer ceramic chip capacitors are available in KEMET's tape and reel packaging, compatible with automatic placement equipment. Bulk cassette packaging is also available (0805,0603 and 0402 only) for those pick and place machines requiring its use.

ELECTRICAL CHARACTERISTICS

1. Working Voltage:

Refers to the maximum continuous DC working voltage permissible across the entire operating temperature range. The reliability of multilayer ceramic capacitors is not extremely sensitive to voltage, and brief applications of voltage above rated will not result in immediate failure. However, reliability will be degraded by sustained exposure to voltages above rated.

2. Temperature Characteristics:

Within the EIA classifications, various temperature characteristics are identified by a three-symbol code; for example: C0G, X7R, X5R, Z5U and Y5V.

For Class I temperature compensating dielectrics (includes C0G), the first symbol designates the significant figures of the temperature coefficient in PPM per degree Celsius, the second designates the multiplier to be applied, and the third designates the tolerance in PPM per degrees Celsius. EIA temperature characteristic codes for Class I dielectrics are shown in Table 1.

Table 1 – EIA Temperature Characteristic Codes for Class I Dielectrics

Significant Figure of Temperature Coefficient		Multiplier Applied to Temperature Coefficient		Tolerance of Temperature Coefficient	
PPM per Degree C	Letter Symbol	Multiplier	Number Symbol	PPM per Degree C	Letter Symbol
0.0	C	-1	0	± 30	G
0.3	B	-10	1	± 60	H
0.9	A	-100	2	± 120	J
1.0	M	-1000	3	± 250	K
1.5	P	-10000	4	± 500	L

KEMET supplies the C0G characteristic.

For Class II and III dielectrics (including X7R, X5R, Z5U & Y5V), the first symbol indicates the lower limit of the operating temperature range, the second indicates the upper limit of the operating temperature range, and the third indicates the maximum capacitance change allowed over the operating temperature range. EIA type designation codes for Class II and III dielectrics are shown in Table 2.

Table 2 – EIA Temperature Characteristic Codes for Class II & III Dielectrics

Low Temperature Rating		High Temperature Rating		Maximum Capacitance Shift		
Degree Celsius	Letter Symbol	Degree Celsius	Number Symbol	Percent	Letter Symbol	EIA Class
+10C	Z	+45C	2	± 1.0%	A	II
-30C	Y	+65C	4	± 1.5%	B	II
-55C	X	+85C	5	± 2.2%	C	II
		+105C	6	± 3.3%	D	II
		+125C	7	± 4.7%	E	II
		+150C	8	± 7.5%	F	II
		+200C	9	± 10.0%	P	II
				± 15.0%	R	II
				± 22.0%	S	III
				+ 22/-33%	T	III
				+22/-56%	U	III
				+22/-82%	V	III

KEMET supplies the X7R, X5R, Z5U and Y5V characteristics.

3. Capacitance Tolerance:

See tables on pages 48-51.

4. Capacitance:

Within specified tolerance when measured per Table 3.

The standard unit of capacitance is the farad. For practical capacitors, capacitance is usually expressed in microfarads (10^{-6} farad), nanofarads (10^{-9} farad), or picofarads (10^{-12} farad). Standard measurement conditions are listed in Table 3 - Specified Electrical Limits.

Like all other practical capacitors, multilayer ceramic capacitors also have resistance and inductance. A simplified schematic for the single frequency equivalent circuit is shown in Figure 1. At high frequency more complex models apply - see KEMET SPICE models at www.kemet.com for details.

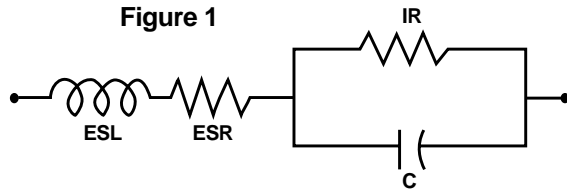

C = Capacitance
 ESL = Equivalent Series Inductance
 ESR = Equivalent Series Resistance
 IR = Insulation Resistance

5. Dissipation Factor: Measured under same conditions as capacitance. (See Table 3)

Dissipation factor (DF) is a measure of the losses in a capacitor under AC application. It is the ratio of the equivalent series resistance to the capacitive reactance, and is usually expressed in percent. It is normally measured simultaneously with capacitance, and under the same conditions. The vector diagram below illustrates the relationship between DF, ESR and impedance. The reciprocal of the dissipation factor is called the "Q" or quality factor. For convenience, the "Q" factor is often used for very low values of dissipation factor especially when measured at high frequencies. DF is sometimes called the "loss tangent" or "tangent δ ", as shown in Figure 2.

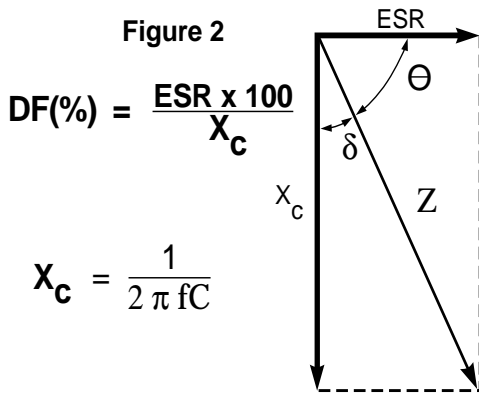

6. Impedance:

Since the parallel resistance (IR) is normally very high, the total impedance of the capacitor can be approximated by:

Figure 3

$$Z = \sqrt{ESR^2 + (X_L - X_C)^2}$$

Where: Z = Total Impedance

ESR = Equivalent Series Resistance

X_C = Capacitive Reactance = $1/(2 \pi fC)$

X_L = Inductive Reactance = $(2 \pi f) (ESL)$

The variation of a capacitor's impedance with frequency determines its effectiveness in many applications. At high frequency more detailed models apply - see KEMET SPICE models for such instances.

7. Insulation Resistance: Measured after 2 minutes electrification at 25°C and rated voltage: Limits per Table 3.

Insulation Resistance is the measure of a capacitor to resist the flow of DC leakage current. It is sometimes referred to as "leakage resistance". Insulation resistance (IR) is the DC resistance measured across the terminals of a capacitor, represented by the parallel resistance (IR) shown in Figure 1. For a given dielectric type, electrode area increases with capacitance, resulting in a decrease in the insulation resistance. Consequently, insulation resistance limits are usually specified as the "RC" (IR x C) product, in terms of ohm-farads or megohm-micro-farads. The insulation resistance for a specific capacitance value is determined by dividing this product by the capacitance. However, as the nominal capacitance values become small, the insulation resistance calculated from the RC product

Table 3 – Specified Electrical Limits

Parameter	Temperature Characteristics			
	C0G	X7R/X5R	Z5U	Y5V
Capacitance & Dissipation Factor: Measured at following conditions: C0G – 1kHz and 1 vrms if capacitance >1000 pF 1MHz and 1 vrms if capacitance ≤1000 pF X7R/X5R/Y5V – 1kHz and 1 vrms* if capacitance ≤ 10 μF X7R/X5R/Y5V – 120Hz and 0.5 vrms if capacitance > 10 μF Z5U – 1kHz and 0.5 vrms Y5V – 1kHz and 1 vrms				
DF Limits:	50 - 200 volts – 0.10% 25 volts – 0.10% 16 volts – ----- 6.3/10 volts – -----	2.5% 3.5% 3.5% 5.0%	4.0% 4.0% ----- -----	5.0% 7.0% 7.0% 10.0%
Dielectric Strength: At 2.5 times rated DC voltage	Pass Subsequent IR Test			
Insulation Resistance (IR): At rated DC voltage, whichever of the two is smaller. To get IR limit, divide MΩ-μF value by the capacitance and compare to GΩ limit. Select the lower of the two limits.	1,000 MΩ – μF or 100 GΩ (100,000 MΩ)	1,000 MΩ – μF or 100 GΩ (100,000 MΩ)	100 MΩ – μF or 10 GΩ (10,000 MΩ)	100 MΩ – μF or 10 G (≥16 volt) 50 MΩ – μF or 10G (≤10v) (10,000 MΩ)
Temperature: Range, °C Capacitance Change (without DC voltage)	-55 to +125 0 ± 30 ppm/°C	X7R: -55 to +125 ±15% X5R: -55 to +85 ±15%	+10 to +85 +22% -56%	-30 to +85 +22% -82%

*Note: Some values measured at ½ volt, see X7R Table for specific details on pages 49 and 50.

reaches values which are impractical. Consequently, IR specifications usually include both a minimum RC product and a maximum limit based on the IR calculated from that value. For example, a typical IR specification might read "1,000 megohm-microfarads or 100 gigohms, whichever is less". The DC leakage current may be calculated by dividing the applied voltage by the insulation resistance (Ohm's Law).

8. Dielectric Withstanding Voltage: 250% of rated voltage for 5 seconds with current limited to 50mA at 25°C. Limits per Table 3.

Dielectric withstanding voltage (DWV) is the peak DC voltage which a capacitor is designed to withstand without damage for short periods of time. All KEMET multilayer ceramic surface mount capacitors will withstand a DC test voltage of 2.5 x the rated voltage for 60 seconds.

KEMET specification limits for all electrical characteristics at standard measurement conditions are shown in Table 3. Variations in these properties caused by changing conditions (temperature, voltage, frequency, and time) are covered in the following sections.

9. Aging Rate: Maximum % Capacitance Loss/Decade Hour
C0G - 0%
X7R - 2.0%
X5R - 2.5%
Z5U - 7.0%
Y5V - 7.0%
Actual rates may be lower. Consult factory for details.

The capacitance of Class II and III dielectric changes with time as well as with temperature, voltage and frequency. The change with time as known as "aging". It is caused by gradual realignment of the crystalline structure of the ceramic dielectric material as it is cooled below its Curie temperature, which produces a loss of capacitance with time. The aging process is predictable and follows a logarithmic decay.

The aging process is reversible. If the capacitor is heated to a temperature above its Curie point for some period of time, de-aging will occur and the capacitor will regain the capacitance lost during the aging process. The amount of de-aging depends on both the elevated temperature and the length of time at that temperature. Exposure to 150°C for one-half hour is sufficient to return the capacitor to its initial value.

Because the capacitance changes rapidly immediately after de-aging, capacitance measurements are usually delayed for at least 10 - 24 hours after the de-aging process, which is often referred to as the "last heat". In addition, manu-

facturers utilize the aging rates to set factory test limits which will bring the capacitance within the specified tolerance at some future time, to allow for customer receipt and use.

10. Effect of Temperature:

Both capacitance and dissipation factor are affected by variations in temperature. The maximum capacitance change with temperature is defined by the temperature characteristic.

However, this only defines an "envelope" bounded by the upper and lower operating temperatures and the minimum and maximum capacitance values. Within this "envelope", the variation with temperature depends upon the specific dielectric formulation.

Insulation resistance decreases with temperature. Typically, the insulation resistance limit at maximum rated temperature is 10% of the 25°C value.

11. Effect of Voltage:

C0G ceramic capacitors are not affected by variations in applied AC or DC voltages. For Class II and III ceramic capacitors (including X7R, X5R, Z5U and Y5V), variations in voltage affect the capacitance and dissipation factor. The application of DC voltages higher than 5 vdc reduces both the capacitance and dissipation factor. The application of AC voltages up to 10-20 vac tends to increase both capacitance and dissipation factor. At higher AC voltages, both capacitance and dissipation factor begin to decrease.

Typical curves showing the effect of applied AC and DC voltage are shown in Figure 7 for KEMET X7R capacitors, and Figure 8 for KEMET Z5U. See SPICE models on the KEMET website for further information.

12. Effect of Frequency:

Frequency affects both capacitance and dissipation factor. Typical curves for KEMET multilayer ceramic capacitors are shown in Figures 4, 5 and 6.

The variation of impedance with frequency is an important consideration in the application of multilayer ceramic capacitors. Total impedance of the capacitor is the vector summation of the capacitive reactance, the inductive reactance, and the ESR, as illustrated in Figure 2. As frequency increases, the capacitive reactance decreases. However, the series inductance (L) shown in Figure 1 produces some inductive reactance, which increases with frequency. At some frequency, the impedance ceases to be capacitive and becomes inductive. This point, at the bottom of the V-shaped impedance versus frequency curves, is the self-resonant frequency. At the self-resonant frequency, the reactance is zero, and the

impedance consists of the ESR only. At high frequency more detailed models apply - See KEMET SPICE models for such instances.

Typical impedance versus frequency curves for KEMET multilayer ceramic capacitors are shown in Figures 4, 5 and 6.

ENVIRONMENTAL AND PHYSICAL

13. **Thermal Shock:**
EIA-198, Method 202, Condition B (5 cycles -55° to + 125°C).
14. **Life Test:**
EIA-198, Method 201, 1000 hours at 200% of rated voltage at 125°C. (Except 85°C for Z5U and Y5V).
See Table 4 on page 46 for limits.
15. **Humidity Test:**
EIA-198, Method 206, (Except 1000 hours, 85°C, 85% RH, Rated Voltage).
See Table 4 on page 46 for limits.
16. **Moisture Resistance:**
EIA-198, Method 204, Condition B (20 cycles with 50 volts applied).
See Table 4 on page 46 for limits.
17. **Solderability:**
EIA-198, Method 301 (245°, 5 secs, Sn62 solder) 95% smooth solder on terminations.
18. **Resistance to Soldering Heat:**
EIA-198, Method 302, Condition B (260°C, 10 seconds) no leaching of nickel barrier.
19. **Terminal Strength:**
EIA-198, Method 303, Condition D .

RELIABILITY

20. A well constructed multilayer ceramic capacitor chip is extremely reliable and, for all practical purposes, has no wearout mechanism when used within the maximum voltage and temperature ratings. Most failures occur as a result of mechanical or thermal damage during mounting on the board, or during subsequent testing. Capacitor failure may also be induced by sustained operation at voltages that exceed the rated DC voltage, voltage spikes or transients that exceed the dielectric's voltage capability, sustained operation at temperatures above the maximum rated temperature, internal defects, or excessive temperature rise due to power dissipation. As with any practical device, multilayer ceramic capacitors also possess an inherent, although low, failure rate when operated within rated conditions. The primary failure mode is by short-circuit or low insulation resistance, resulting from cracks or from dielectric breakdown at a defect site. KEMET monitors reliability with a periodic sampling program for select-

ed values. Results are available in our FIT (Failure in Time) report for commercial chips.

21. Storage and Handling:

Ceramic chip capacitors should be stored in normal working environments. While the chips themselves are quite robust in other environments, solderability will be degraded by exposure to high temperatures, high humidity, corrosive atmospheres, and long term storage. In addition, packaging materials will be degraded by high temperature – reels may soften or warp, and tape peel force may increase. KEMET recommends that maximum storage temperature not exceed 40 degrees C, and maximum storage humidity not exceed 70% relative humidity. In addition, temperature fluctuations should be minimized to avoid condensation on the parts, and atmospheres should be free of chlorine and sulfur bearing compounds. For optimized solderability, chip stock should be used promptly, preferably within 1.5 years of receipt.

MISAPPLICATION

22. Ceramic capacitors, like any other capacitors, may fail if they are misapplied. Some misapplications include mechanical damage, such as impact or excessive flexing of the circuit board. Others include severe mounting or rework cycles that may also introduce thermal shock. Still others include exposure to excessive voltage, current or temperature. If the dielectric layer of the capacitor is damaged by misapplication, the circuit may fail. The electrical energy of the circuit can be released as heat, which may damage the circuit board and other components as well.

ADDITIONAL INFORMATION

23. Detailed application information can be found in KEMET Engineering Bulletins.
 - F-2100 Surface Mount-Mounting Pad Dimensions and Considerations
 - F-2102 Reflow Soldering Process
 - F-2105 Wave Solder Process
 - F-2103 Surface Mount Repair
 - F-2110 Capacitance Monitoring while Flex Testing

For analysis of high frequency applications, KEMET has SPICE models of most chip capacitors. Models may be downloaded from KEMET's website www.kemet.com.

Additional information is also available - See your KEMET representative for details or post your questions to KEMET's homepage on the web <http://www.kemet.com>.

TABLE 4 – ENVIRONMENTAL LIMITS

Body	Rated DC Voltage	Initial DF (%)	IR (GΩ or ΩF) whichever is less	DF (%) Post Life/ Hum/Moisture Resistance	Cap Shift (% or pf, whichever is greater) Post Life/ Hum/Moisture Resistance	IR (GΩ or ΩF) whichever is less Post Life/ Hum/Moisture Resistance
C0G	200*	0.1	100/1000	0.5	0.3% or ± 0.25 pf	10/100
	100	0.1	100/1000	0.5	0.3% or ± 0.25 pf	10/100
	50	0.1	100/1000	0.5	0.3% or ± 0.25 pf	10/100
	25	0.1	100/1000	0.5	0.3% or ± 0.25 pf	10/100
	16	0.1	100/1000	0.5	0.3% or ± 0.25 pf	10/100
X7R/X5R	200*	2.5	100/1000	3.0	± 20%	10/100
	100	2.5	100/1000	3.0	± 20%	10/100
	50	2.5	100/1000	3.0	± 20%	10/100
	25	3.5	100/1000	5.0	± 20%	10/100
	16	3.5	100/1000	5.0	± 20%	10/100
	6.3/10	5.0	100/1000	7.5	± 20%	10/100
Z5U	100	4.0	10/100	5.0	± 30%	1/10
	50	4.0	10/100	5.0	± 30%	1/10
	25	4.0	10/100	7.5	± 30%	1/10
Y5V	100	5.0	10/100	7.5	± 30%	1/10
	50	5.0	10/100	7.5	± 30%	1/10
	25	7.0	10/100	10.0	± 30%	1/10
	16	7.0	10/100	10.0	± 30%	1/10
	6.3/10	10.0	10/50	15.0	± 30%	1/5

*200 Volt limits not currently included in EIA-198.

TYPICAL PERFORMANCE CURVES EFFECT OF FREQUENCY (See SPICE models for specific ratings.)

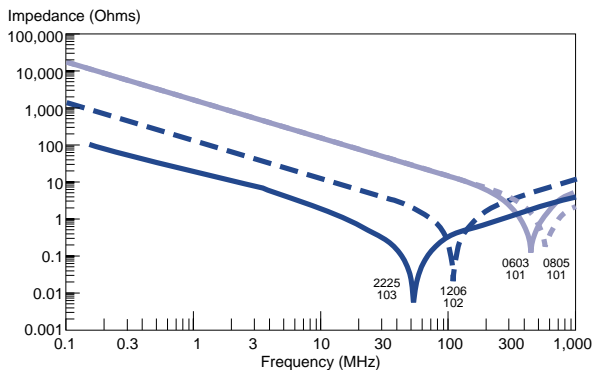

FIGURE 4. Impedance versus Frequency C0G Dielectric

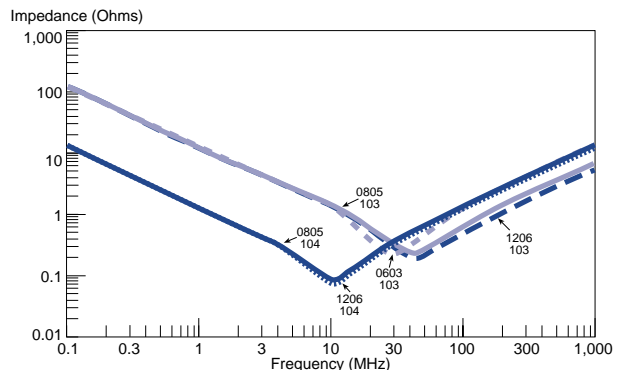

FIGURE 5. Impedance versus Frequency X7R Dielectric

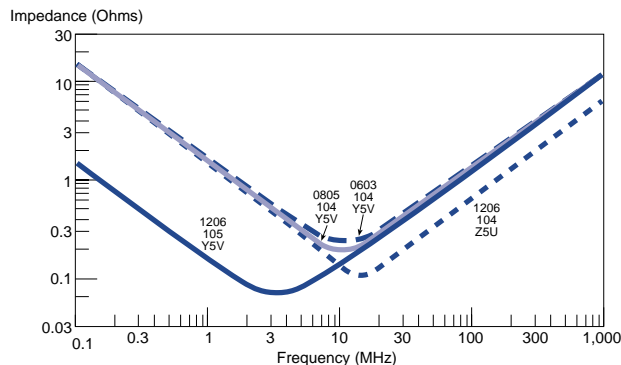
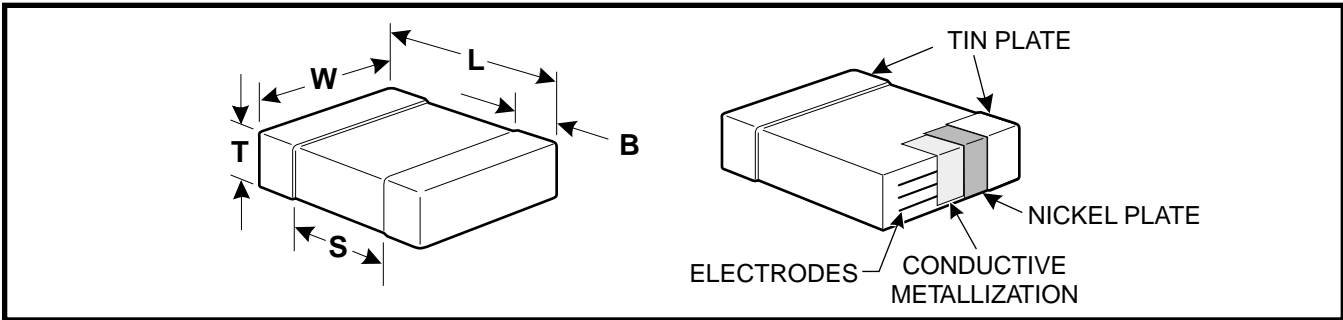

FIGURE 6. Impedance versus Frequency Z5U/Y5V Dielectric

FEATURES

- COG (NP0), X7R, X5R, Z5U and Y5V Dielectrics
- 10, 16, 25, 50, 100 and 200 Volts
- Standard End Metallization: Tin-plate over nickel barrier
- Available Capacitance Tolerances: ± 0.10 pF; ± 0.25 pF; ± 0.5 pF; $\pm 1\%$; $\pm 2\%$; $\pm 5\%$; $\pm 10\%$; $\pm 20\%$; and $+80\%$ - 20%
- Tape and reel packaging per EIA481-1. (See page 61 for specific tape and reel information.) Bulk Cassette packaging (0402, 0603, 0805 only) per IEC60286-6 and EIAJ 7201.

CAPACITOR OUTLINE DRAWINGS



DIMENSIONS—MILLIMETERS AND (INCHES)

EIA SIZE CODE	METRIC SIZE CODE (Ref only)	L # LENGTH	W # WIDTH	See pages 48-52 for thickness dimensions.	B BANDWIDTH	S MIN. SEPARATION	MOUNTING TECHNIQUE
0402*	1005	1.0 (.04) \pm .05 (.002)	0.5 (.02) \pm .05 (.002)		0.20 (0.008)-0.40 (0.016)	0.3 (.012)	Solder Reflow
0603*	1608	1.6 (.063) \pm 0.15 (.006)	0.8 (.032) \pm 0.15 (.006)		0.35 (.014) \pm 0.15 (.006)	0.7 (.028)	Solder Wave † or Solder Reflow
0805*	2012	2.0 (.079) \pm 0.2 (.008)	1.25 (.049) \pm 0.2 (.008)		0.5 (.02) \pm .25 (.010)	0.75 (.030)	
1206*	3216	3.2 (.126) \pm 0.2 (.008)	1.6 (.063) \pm 0.2 (.008)		0.5 (.02) \pm .25 (.010)	N/A	
1210*	3225	3.2 (.126) \pm 0.2 (.008)	2.5 (.098) \pm 0.2 (.008)		0.5 (.02) \pm .25 (.010)	N/A	Solder Reflow
1812	4532	4.5 (.177) \pm 0.3 (.012)	3.2 (.126) \pm 0.3 (.012)		0.6 (.024) \pm .35 (.014)	N/A	
1825*	4564	4.5 (.177) \pm 0.3 (.012)	6.4 (.252) \pm 0.4 (.016)		0.6 (.024) \pm .35 (.014)	N/A	
2220	5650	5.6 (.220) \pm 0.4 (.016)	5.0 (.197) \pm 0.4 (.016)		0.6 (.024) \pm .35 (.014)	N/A	
2225	5664	5.6 (.220) \pm 0.4 (.016)	6.3 (.248) \pm 0.4 (.016)		0.6 (.024) \pm .35 (.014)	N/A	

* Note: Indicates EIA Preferred Case Sizes (Tightened tolerances apply for 0402, 0603, and 0805 packaged in bulk cassette, see page 65.)

#Note: These thicknesses are EIA maximums. Most chips are considerably thinner. Consult factory for details. Also, some extended values may be slightly thicker than EIA maximums.

† For extended value 1210 case size - solder reflow only.

CAPACITOR ORDERING INFORMATION (Standard Chips - For Military see page 55)

CERAMIC SIZE CODE SPECIFICATION C - Standard

CAPACITANCE CODE Expressed in Picofarads (pF)
First two digits represent significant figures.
Third digit specifies number of zeros. (Use 9 for 1.0 through 9.9pF. Use 8 for 0.5 through 0.99pF)
(Example: 2.2pF = 229 or 0.50 pF = 508)

CAPACITANCE TOLERANCE

B - ± 0.10 pF	J - $\pm 5\%$
C - ± 0.25 pF	K - $\pm 10\%$
D - ± 0.5 pF	M - $\pm 20\%$
F - $\pm 1\%$	P - (GMV) - special order only
G - $\pm 2\%$	Z - $+80\%$, -20%

END METALLIZATION
C - Standard (Tin-plated nickel barrier)

FAILURE RATE LEVEL
A - Not Applicable

TEMPERATURE CHARACTERISTIC
Designated by Capacitance Change Over Temperature Range

G - COG (NP0) (± 30 PPM/ $^{\circ}$ C)
R - X7R ($\pm 15\%$) (-55° C + 125° C)
P - X5R ($\pm 15\%$) (-55° C + 85° C)
U - Z5U ($+22\%$, -56%) ($+10^{\circ}$ C + 85° C)
V - Y5V ($+22\%$, -82%) (-30° C + 85° C)

VOLTAGE

1 - 100V	3 - 25V
2 - 200V	4 - 16V
5 - 50V	8 - 10V
	9 - 6.3V

*** Part Number Example: C0805C103K5RAC (14 digits - no spaces)**

C0G CAPACITANCE RANGE – 1210, 1812, 1825, 2220, 2225

CAP. PF	CAP. CODE	CAP. TOL.	C1210*			C1812*			C1825*			C2220			C2225		
			50V	100V	200V	50V	100V	200V	50V	100V	200V	50V	100V	200V	50V	100V	200V
10	100	D	J,K,M	FB	FB	FB											
12	120	D	J,K,M	FB	FB	FB											
15	150	D	G,J,K,M	FB	FB	FB											
18	180	D	G,J,K,M	FB	FB	FB											
22	220	D	G,J,K,M	FB	FB	FB											
27	270	D,F,G	J,K,M	FB	FB	FB											
33	330	D,F,G	J,K,M	FB	FB	FB											
39	390	D,F,G	J,K,M	FB	FB	FB											
47	470	D,F,G	J,K,M	FB	FB	FB											
56	560	F,G	J,K,M	FB	FB	FB											
68	680	F,G	J,K,M	FB	FB	FB											
82	820	F,G	J,K,M	FB	FB	FB											
100	101	F,G	J,K,M	FB	FB	FB											
120	121	F,G	J,K,M	FB	FB	FB											
150	151	F,G	J,K,M	FB	FB	FB											
180	181	F,G	J,K,M	FB	FB	FB											
220	221	F,G	J,K,M	FB	FB	FB											
270	271	F,G	J,K,M	FB	FB	FB											
330	331	F,G	J,K,M	FB	FB	FB											
390	391	F,G	J,K,M	FB	FB	FB											
470	471	F,G	J,K,M	FB	FB	FB	GB	GB	GB								
560	561	F,G	J,K,M	FB	FB	FB	GB	GB	GB								
680	681	F,G	J,K,M	FB	FB	FB	GB	GB	GB								
820	821	F,G	J,K,M	FB	FB	FB	GB	GB	GB								
1000	102	F,G	J,K,M	FB	FB	FB	GB	GB	GB								
1200	122	F,G	J,K,M	FB	FB	FB	GB	GB	GB								
1500	152	F,G	J,K,M	FB	FB	FE	GB	GB	GB								
1800	182	F,G	J,K,M	FB	FB	FE	GB	GB	GB								
2200	222	F,G	J,K,M	FB	FC	FG	GB	GB	GB								
2700	272	F,G	J,K,M	FB	FC	FC	GB	GB	GB								
3300	332	F,G	J,K,M	FB	FF	FF	GB	GB	GB								
3900	392	F,G	J,K,M	FB	FF		GB	GB	GB	HB	HB	HB					
4700	472	F,G	J,K,M	FB	FF		GB	GB	GD	HB	HB	HB					
5600	562	F,G	J,K,M	FB	FF		GB	GB	GF	HB	HB	HB					
6800	682	F,G	J,K,M	FB	FG		GB	GB	GJ	HB	HB	HB					
8200	822	F,G	J,K,M	FC			GB	GB		HB	HB	HB					
10,000	103	F,G	J,K,M	FF			GB	GD		HB	HB	HE					
12,000	123	F,G	J,K,M	FG						HB	HB	HE					
15,000	153	F,G	J,K,M							HB	HB	HE					
18,000	183	F,G	J,K,M							HB	HB	HE					
22,000	223	F,G	J,K,M							HB	HE						
27,000	273	F,G	J,K,M							HB	HE						
33,000	333	F,G	J,K,M							HB	HE						

X7R CAPACITANCE RANGE – 0402, 0603, 0805, 1206

CAP. PF	CAP. CODE	CAP. TOL.	C0402*				C0603*				C0805*				C1206*							
			6.3V	10V	16V	25V	50V	6.3V	10V	16V	25V	50V	100V	200V	6.3V	10V	16V	25V	50V	100V	200V	
150	151	K,M,J	BB	BB	BB	BB	BB	CB	CB	CB	CB	CB	CB	CB	CB	CB	CB	CB	CB	CB	CB	CB
180	181	K,M,J	BB	BB	BB	BB	BB	CB	CB	CB	CB	CB	CB	CB	CB	CB	CB	CB	CB	CB	CB	CB
220	221	K,M,J	BB	BB	BB	BB	BB	CB	CB	CB	CB	CB	CB	CB	CB	CB	CB	CB	CB	CB	CB	CB
270	271	K,M,J	BB	BB	BB	BB	BB	CB	CB	CB	CB	CB	CB	CB	CB	CB	CB	CB	CB	CB	CB	CB
330	331	K,M,J	BB	BB	BB	BB	BB	CB	CB	CB	CB	CB	CB	CB	CB	CB	CB	CB	CB	CB	CB	CB
390	391	K,M,J	BB	BB	BB	BB	BB	CB	CB	CB	CB	CB	CB	CB	CB	CB	CB	CB	CB	CB	CB	CB
470	471	K,M,J	BB	BB	BB	BB	BB	CB	CB	CB	CB	CB	CB	CB	CB	CB	CB	CB	CB	CB	CB	CB
560	561	K,M,J	BB	BB	BB	BB	BB	CB	CB	CB	CB	CB	CB	CB	CB	CB	CB	CB	CB	CB	CB	CB
680	681	K,M,J	BB	BB	BB	BB	BB	CB	CB	CB	CB	CB	CB	CB	CB	CB	CB	CB	CB	CB	CB	CB
820	821	K,M,J	BB	BB	BB	BB	BB	CB	CB	CB	CB	CB	CB	CB	CB	CB	CB	CB	CB	CB	CB	CB
1000	102	K,M,J	BB	BB	BB	BB	BB	CB	CB	CB	CB	CB	CB	CB	CB	CB	CB	CB	CB	CB	CB	CB
1200	122	K,M,J	BB	BB	BB	BB	BB	CB	CB	CB	CB	CB	CB	CB	CB	CB	CB	CB	CB	CB	CB	CB
1500	152	K,M,J	BB	BB	BB	BB	BB	CB	CB	CB	CB	CB	CB	CB	CB	CB	CB	CB	CB	CB	CB	CB
1800	182	K,M,J	BB	BB	BB	BB	BB	CB	CB	CB	CB	CB	CB	CB	CB	CB	CB	CB	CB	CB	CB	CB
2200	222	K,M,J	BB	BB	BB	BB	BB	CB	CB	CB	CB	CB	CB	CB	CB	CB	CB	CB	CB	CB	CB	CB
2700	272	K,M,J	BB	BB	BB	BB	BB	CB	CB	CB	CB	CB	CB	CB	CB	CB	CB	CB	CB	CB	CB	CB
3300	332	K,M,J	BB	BB	BB	BB	BB	CB	CB	CB	CB	CB	CB	CB	CB	CB	CB	CB	CB	CB	CB	CB
3900	392	K,M,J	BB	BB	BB	BB	BB	CB	CB	CB	CB	CB	CB	CB	CB	CB	CB	CB	CB	CB	CB	CB
4700	472	K,M,J	BB	BB	BB	BB	BB	CB	CB	CB	CB	CB	CB	CB	CB	CB	CB	CB	CB	CB	CB	CB
5600	562	K,M,J	BB	BB	BB	BB	BB	CB	CB	CB	CB	CB	CB	CB	CB	CB	CB	CB	CB	CB	CB	CB
6800	682	K,M,J	BB	BB	BB	BB	BB	CB	CB	CB	CB	CB	CB	CB	CB	CB	CB	CB	CB	CB	CB	CB
8200	822	K,M,J	BB	BB	BB	BB	BB	CB	CB	CB	CB	CB	CB	CB	CB	CB	CB	CB	CB	CB	CB	CB
10,000	103	K,M,J	BB	BB	BB	BB	BB	CB	CB	CB	CB	CB	CB	CB	CB	CB	CB	CB	CB	CB	CB	CB
12,000	123	K,M,J						CB	CB	CB	CB	CB	CB	CB	CB	CB	CB	CB	CB	CB	CB	CB
15,000	153	K,M,J						CB	CB	CB	CB	CB	CB	CB	CB	CB	CB	CB	CB	CB	CB	CB
18,000	183	K,M,J						CB	CB	CB	CB	CB	CB	CB	CB	CB	CB	CB	CB	CB	CB	CB
22,000	223	K,M,J						CB	CB	CB	CB	CB	CB	CB	CB	CB	CB	CB	CB	CB	CB	CB
27,000	273	K,M,J						CB	CB	CB	CB	CB	CB	CB	CB	CB	CB	CB	CB	CB	CB	CB
33,000	333	K,M,J						CB	CB	CB	CB	CB	CB	CB	CB	CB	CB	CB	CB	CB	CB	CB
39,000	393	K,M,J						CB	CB	CB	CB	CB	CB	CB	CB	CB	CB	CB	CB	CB	CB	CB
47,000	473	K,M,J						CB	CB	CB	CB	CB	CB	CB	CB	CB	CB	CB	CB	CB	CB	CB
56,000	563	K,M,J						CB	CB	CB	CB	CB	CB	CB	CB	CB	CB	CB	CB	CB	CB	CB
68,000	683	K,M,J						CB	CB	CB	CB	CB	CB	CB	CB	CB	CB	CB	CB	CB	CB	CB
82,000	823	K,M,J						CB	CB	CB	CB	CB	CB	CB	CB	CB	CB	CB	CB	CB	CB	CB
100,000	104	K,M,J						CB#	CB#	CB#	CB#	CB#	CB#	CB#	CB#	CB#	CB#	CB#	CB#	CB#	CB#	CB#
120,000	124	K,M,J						CB#	CB#	CB#	CB#	CB#	CB#	CB#	CB#	CB#	CB#	CB#	CB#	CB#	CB#	CB#
150,000	154	K,M,J						CB#	CB#	CB#	CB#	CB#	CB#	CB#	CB#	CB#	CB#	CB#	CB#	CB#	CB#	CB#
180,000	184	K,M,J						CB#	CB#	CB#	CB#	CB#	CB#	CB#	CB#	CB#	CB#	CB#	CB#	CB#	CB#	CB#
220,000	224	K,M,J						CB#	CB#	CB#	CB#	CB#	CB#	CB#	CB#	CB#	CB#	CB#	CB#	CB#	CB#	CB#
270,000	274	K,M,J						CB#	CB#	CB#	CB#	CB#	CB#	CB#	CB#	CB#	CB#	CB#	CB#	CB#	CB#	CB#
330,000	334	K,M,J						CB#	CB#	CB#	CB#	CB#	CB#	CB#	CB#	CB#	CB#	CB#	CB#	CB#	CB#	CB#
390,000	394	K,M,J						CB#	CB#	CB#	CB#	CB#	CB#	CB#	CB#	CB#	CB#	CB#	CB#	CB#	CB#	CB#
470,000	474	K,M,J						DG	DG	DG	DG	DG	DG	DG	DG	DG	DG	DG	DG	DG	DG	DG
560,000	564	K,M,J						DG	DG	DG	DG	DG	DG	DG	DG	DG	DG	DG	DG	DG	DG	DG
680,000	684	K,M,J						DG	DG	DG	DG	DG	DG	DG	DG	DG	DG	DG	DG	DG	DG	DG
820,000	824	K,M,J						DG	DG	DG	DG	DG	DG	DG	DG	DG	DG	DG	DG	DG	DG	DG
1,000,000	105	K,M,J						DG	DG	DG	DG	DG	DG	DG	DG	DG	DG	DG	DG	DG	DG	DG
1,200,000	125	K,M,J						DG	DG	DG	DG	DG	DG	DG	DG	DG	DG	DG	DG	DG	DG	DG
1,500,000	155	K,M,J						DG	DG	DG	DG	DG	DG	DG	DG	DG	DG	DG	DG	DG	DG	DG
1,800,000	185	K,M,J						DG	DG	DG	DG	DG	DG	DG	DG	DG	DG	DG	DG	DG	DG	DG
2,200,000	225	K,M,J	</																			

X7R CAPACITANCE RANGE – 1210, 1812, 1825, 2220, 2225

CAP. PF	CAP CODE	CAP. TOL.	C1210*							C1812*			C1825*			C2220			C2225		
			6.3V	10V	16V	25V	50V	100V	200V	50V	100V	200V	50V	100V	200V	50V	100V	200V	50V	100V	200V
2200	222	K,M,J	FB	FB	FB	FB	FB	FB	FB												
2700	272	K,M,J	FB	FB	FB	FB	FB	FB	FB												
3300	332	K,M,J	FB	FB	FB	FB	FB	FB	FB												
3900	392	K,M,J	FB	FB	FB	FB	FB	FB	FB												
4700	472	K,M,J	FB	FB	FB	FB	FB	FB	FB												
5600	562	K,M,J	FB	FB	FB	FB	FB	FB	FB												
6800	682	K,M,J	FB	FB	FB	FB	FB	FB	FB	GB	GB	GB									
8200	822	K,M,J	FB	FB	FB	FB	FB	FB	FB	GB	GB	GB									
10,000	103	K,M,J	FB	FB	FB	FB	FB	FB	FB	GB	GB	GB									
12,000	123	K,M,J	FB	FB	FB	FB	FB	FB	FB	GB	GB	GB									
15,000	153	K,M,J	FB	FB	FB	FB	FB	FB	FB	GB	GB	GB									
18,000	183	K,M,J	FB	FB	FB	FB	FB	FB	FB	GB	GB	GB									
22,000	223	K,M,J	FB	FB	FB	FB	FB	FB	FB	GB	GB	GB	HB	HB	HB						
27,000	273	K,M,J	FB	FB	FB	FB	FB	FB	FB	GB	GB	GB	HB	HB	HB						
33,000	333	K,M,J	FB	FB	FB	FB	FB	FB	FB	GB	GB	GB	HB	HB	HB						
39,000	393	K,M,J	FB	FB	FB	FB	FB	FB	FB	GB	GB	GB	HB	HB	HB						
47,000	473	K,M,J	FB	FB	FB	FB	FB	FB	FB	FC	GB	GB	HB	HB	HB				KC	KC	KC
56,000	563	K,M,J	FB	FB	FB	FB	FB	FB	FB	FC	GB	GB	HB	HB	HB				KC	KC	KC
68,000	683	K,M,J	FB	FB	FB	FB	FB	FB	FB	FC	GB	GB	HB	HB	HB				KC	KC	KC
82,000	823	K,M,J	FB	FB	FB	FB	FC	FC	FC	GB	GB	GB	HB	HB	HB				KC	KC	KC
100,000	104	K,M,J	FB	FB	FB	FB	FD	FD	FD	GB	GB	GB	HB	HB	HB				KC	KC	KC
120,000	124	K,M,J	FB	FB	FB	FB	FD	FD	FD	GB	GB	GB	HB	HB	HB				KC	KC	KC
150,000	154	K,M,J	FC	FC	FC	FC	FD	FD	FD	GB	GB	GE	HB	HB	HB				KC	KC	KC
180,000	184	K,M,J	FC	FC	FC	FC	FD	FD	FD	GB	GB	GG	HB	HB	HB				KC	KC	KC
220,000	224	K,M,J	FC	FC	FC	FC	FD	FD	FD	GB	GB		HB	HB	HB				KC	KC	KC
270,000	274	K,M,J	FC	FC	FC	FC	FD#	FD#	FD#	GB	GH		HB	HB	HB	JC	JC	JC	KB	KC	KC
330,000	334	K,M,J	FD	FD	FD	FD	FD#	FD#	FD#	GB	GH		HB	HB	HB	JC	JC	JC	KB	KC	KC
390,000	394	K,M,J	FD	FD	FD	FD	FD#	FD#	FD#	GB			HB	HB	HD	JC	JC	JC	KB	KC	KC
470,000	474	K,M,J	FD	FD	FD	FD	FD#	FD#	FD#	GB			HB	HB	HD	JC	JC	JC	KB	KC	KD
560,000	564	K,M,J	FD	FD	FD	FD	FD#	FD#	FD#	GC			HB	HB	HD	JC	JC	JC	KB	KC	
680,000	684	K,M,J	FD	FD	FD	FD	FD#	FD#	FD#	GC			HB	HD		JC	JC	JD	KB	KC	
820,000	824	K,M,J	FF	FF	FF	FF				GE			HB			JC	JC		KB	KC	
1,000,000	105	K,M,J	FH	FH	FH	FH	FH#			GE			HB			JC	JC		KB	KD	
1,200,000	125	K,M,J	FH	FH	FH	FH							HB			JC	JC		KB		
1,500,000	155	K,M,J	FH	FH	FH	FH							HB			JC	JC		KB		
1,800,000	185	K,M,J	FH	FH	FH	FH							HD			JC	JC		KD		
2,200,000	225	K,M,J	FJ	FJ	FJ	FJ							HF			JF	JF		KD		

* Indicates EIA preferred chip sizes.
 NOTE: For non-standard capacitance values or voltages, contact your local KEMET sales representative.
 50 Volt Ceramic Chips can be used for 63 volt applications.
 # Extended Range Values — Cap and DF measured @ 0.5 Vms.

X5R CAPACITANCE RANGE

CAP. pF	CAP CODE	CAP. TOL	C0402*		C0603*		C0805*		C1206*				C1210*								
			6.3V	10V	6.3V	10V	6.3V	10V	6.3V	10V	16V	25V	6.3V	10V	16V	25V	50V				
12,000	123	K,M	BB	BB																	
15,000	153	K,M	BB	BB																	
18,000	183	K,M	BB	BB																	
22,000	223	K,M	BB	BB																	
27,000	273	K,M	BB	BB																	
33,000	333	K,M	BB	BB																	
39,000	393	K,M	BB	BB																	
47,000	473	K,M	BB	BB																	
56,000	563	K,M	BB	BB																	
68,000	683	K,M	BB	BB																	
82,000	823	K,M	BB	BB																	
100,000	104	K,M	BB	BB									EB								
120,000	124	K,M											EC								
150,000	154	K,M											EC								
180,000	184	K,M											EC								
220,000	224	K,M											EC								
270,000	274	K,M											EB								
330,000	334	K,M			CC	CC							EB								
390,000	394	K,M			CC	CC							EB								
470,000	474	K,M			CC	CC							EC								
560,000	564	K,M			CC	CC							ED								
680,000	684	K,M			CC	CC							EE								
820,000	824	K,M			CC	CC							EE								
1,000,000	105	K,M			CC	CC							EH						FH+	FH+	FH+
1,200,000	125	K,M					DD	DD					EC						FD+	FD+	
1,500,000	155	K,M					DE	DE	EC	EC	EC	EC	EC						FD+	FD+	
1,800,000	185	K,M					DH	DH	EE	EE	EE	EE	EE						FD+	FD+	
2,200,000	225	K,M					DH	DH	EE	EE	EE	EE	EE						FG+	FG+	
2,700,000	275	K,M					DD	DD	EF	EF	EF	EF	EF						FG+	FG+	
3,300,000	335	K,M					DE	DE	EH	EH	EH	EH	EH						FH+	FH+	
4,700,000	475	K,M					DD	DD	EH	EH	EH	EH	EH						FK+	FK+	
6,800,000	685	K,M					DD	DD	EH	EH	EH	EH	EH						FJ+	FJ+	
8,200,000	825	K,M					DD	DD	EH	EH	EH	EH	EH						FK+	FK+	
10,000,000	106	K,M					DD	DD	EH	EH	EH	EH	EH						FK+	FK+	

NOTE: For non-standard capacitance values or voltages, contact your local KEMET sales representative.
 + Reflow only

See page 52 for Thickness Code Reference Chart.

Z5U CAPACITANCE RANGE (KEMET's Z5U also meets Y5V Characteristics)

CAP. PF	CAP CODE	CAP TOL	C0805*		C1206*		C1210*		C1812*		C1825*		C2225	
			50V	100V	50V	100V	50V	100V	50V	100V	50V	100V	50V	100V
6800	682	M,Z	DC	DC										
8200	822	M,Z	DC	DC										
10,000	103	M,Z	DC	DC	EB	EB								
12,000	123	M,Z	DC		EB	EB								
15,000	153	M,Z	DC		EB	EB								
18,000	183	M,Z	DC		EB	EB								
22,000	223	M,Z	DC		EB	EB								
27,000	273	M,Z	DC		EB	EB								
33,000	333	M,Z	DC		EB	EB								
39,000	393	M,Z	DD		EB	EC								
47,000	473	M,Z	DD		EB	EC	FB	FB						
56,000	563	M,Z	DD		EB	EB	FB	FB						
68,000	683	M,Z	DD		EB	EB	FB	FB						
82,000	823	M,Z	DD		EB	EB	FB	FC	GB	GB				
100,000	104	M,Z	DD		EB	EB	FB	FD	GB	GB				
120,000	124	M,Z			EC		FB	FD	GB	GB				
150,000	154	M,Z			EC		FC	FD	GB	GB				
180,000	184	M,Z			EC		FC		GB		HB	HB		
220,000	224	M,Z			EC		FC		GB		HB	HB		
270,000	274	M,Z					FC		GB		HB	HB		
330,000	334	M,Z					FD		GB		HB	HB	KB	KB
390,000	394	M,Z					FD		GB		HB	HD	KB	KB
470,000	474	M,Z					FD		GB		HB		KB	KB
560,000	564	M,Z					FD		GC		HB		KB	KB
680,000	684	M,Z					FD		GC		HB		KB	KB
820,000	824	M,Z						FF	GE		HB		KB	KB
1,000,000	105	M,Z						FH	GE		HB		KB	KB
1,200,000	125	M,Z									HB		KB	KB
1,500,000	155	M,Z									HB		KB	KB
1,800,000	185	M,Z									HB		KD	KD
2,200,000	225	M,Z									HB		KD	KD

NOTE: For non-standard capacitance values or voltages, contact your local KEMET sales representative.
50 Volt Ceramic Chips can be used for 63 volt applications.
* EIA preferred chip sizes

Y5V CAPACITANCE RANGE

Cap. pF	CAP CODE	Cap. Tol.	C0402			C0603				C0805					C1206					C1210									
			6.3V	10V	16V	6.3V	10V	16V	25V	6.3V	10V	16V	25V	50V	6.3V	10V	16V	25V	50V	6.3V	10V	16V	25V	50V					
10,000	103	Z	BB	BB	BB																								
12,000	123	Z	BB	BB	BB																								
15,000	153	Z	BB	BB	BB																								
22,000	223	Z	BB	BB	BB								DC										EB						
33,000	333	Z	BB	BB	BB								DC										EB						
47,000	473	Z	BB	BB	BB								DD										EB						
68,000	683	Z	BB	BB	BB								DD										EB						
100,000	104	Z	BB	BB	BB	CB	CB	CB	CB				DD										EB						
150,000	154	Z				CB	CB	CB	CB				DD										EB						
220,000	224	Z				CB	CB	CB	CB	DC	DC	DC	DC													FD+	FD+		
330,000	334	Z				CB	CB	CB	CB	DC	DC	DC	DC													FD+	FD+		
470,000	474	Z								DC	DC	DC	DC										EC				FD+	FD+	
680,000	684	Z								DE	DE	DE	DE										EB				FD+	FD+	
1,000,000	105	Z								DG	DG	DG	DG										EB				FD+	FD+	
1,500,000	155	Z								DG	DG	DG	DG	EC	EC	EC	EC						EB				FH+	FH+	
2,200,000	225	Z								DG	DG	DG	DG	ED	ED	ED	ED												
3,300,000	335	Z												EF	EF	EF	EF												
4,700,000	475	Z												EJ	EJ	EJ	EJ										FG+	FG+	
6,800,000	685	Z												EJ	EJ	EJ	EJ										FG+	FG+	
10,000,000	106	Z												EJ	EJ	EJ	EJ										FJ+	FJ+	
15,000,000	156	Z												EJ	EJ	EJ	EJ										FJ+	FJ+	
22,000,000	226	Z																									FK+	FK+	

NOTE: For non-standard capacitance values or voltages, contact your local KEMET sales representative.
50 Volt Ceramic Chips can be used for 63 volt applications.
* EIA preferred chip sizes
+ Reflow only

See page 52 for Thickness Code Reference Chart.

SURFACE MOUNT LAND DIMENSIONS - CERAMIC CHIP CAPACITORS - MM

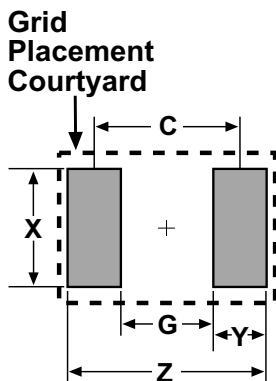

Dimension	Reflow Solder					Wave Solder				
	Z	G	X	Y(ref)	C(ref)	Z	G	X	Y(ref)	Smin
0402	2.14	0.28	0.74	0.93	1.21	Not Recommended				
0603	2.78	0.68	1.08	1.05	1.73	3.18	0.68	0.80	1.25	1.93
0805	3.30	0.70	1.60	1.30	2.00	3.70	0.70	1.10	1.50	2.20
1206	4.50	1.50	2.00	1.50	3.00	4.90	1.50	1.40	1.70	3.20
1210	4.50	1.50	2.90	1.50	3.00	4.90	1.50	2.00	1.70	3.20
1812	5.90	2.30	3.70	1.80	4.10	6.30	2.30	2.60	2.00	4.30
1825	5.90	2.30	6.90	1.80	4.10	Not Recommended				
2220	7.00	3.30	5.50	1.85	5.15	Not Recommended				
2225	7.00	3.30	6.80	1.85	5.15	Not Recommended				

Calculation Formula
 $Z = L_{min} + 2Jt + Tt$
 $G = S_{max} - 2Jh - Th$
 $X = W_{min} + 2Js + Ts$
 $Tt, Th, Ts = \text{Combined tolerances}$

THICKNESS CODE REFERENCE CHART PACKAGING QTY BASED ON FINISHED CHIP THICKNESS SPECIFICATIONS

Thickness Code	Chip Size	Chip Thickness Range (mm)	Qty per Reel 7" Plastic	Qty per Reel 13" Plastic	Qty per Reel 7" Paper	Qty per Reel 13" Paper	Qty per Bulk Cassette
AA	0201	.30 ± .03	N/A	N/A	15,000	N/A	N/A
BB	0402	.50 ± .05	N/A	N/A	10,000	50,000	50,000
CB	0603	.80 ± .07	N/A	N/A	4,000	10,000	15,000
CC	0603	.80 ± .10	N/A	N/A	4,000	10,000	N/A
DB	0805	.60 ± .10	N/A	N/A	N/A	N/A	10,000
DC	0805	.78 ± .10	4,000	10,000	4,000	10,000	N/A
DD	0805	.90 ± .10	4,000	10,000	N/A	N/A	N/A
DE	0805	1.00 ± .10	2,500	10,000	N/A	N/A	N/A
DF	0805	1.10 ± .10	2,500	10,000	N/A	N/A	N/A
DG	0805	1.25 ± .15	2,500	10,000	N/A	N/A	N/A
DH	0805	1.25 ± .20	2,500	10,000	N/A	N/A	N/A
EB	1206	.78 ± .10	4,000	10,000	4,000	10,000	N/A
EC	1206	.90 ± .10	4,000	10,000	N/A	N/A	N/A
ED	1206	1.00 ± .10	2,500	10,000	N/A	N/A	N/A
EE	1206	1.10 ± .10	2,500	10,000	N/A	N/A	N/A
EF	1206	1.20 ± .15	2,500	10,000	N/A	N/A	N/A
EG	1206	1.60 ± .15	2,000	8,000	N/A	N/A	N/A
EH	1206	1.60 ± .20	2,000	8,000	N/A	N/A	N/A
EJ	1206	1.70 ± .20	2,000	8,000	N/A	N/A	N/A
FB	1210	.78 ± .10	4,000	10,000	N/A	N/A	N/A
FC	1210	.90 ± .10	4,000	10,000	N/A	N/A	N/A
FD	1210	.95 ± .10	4,000	10,000	N/A	N/A	N/A
FE	1210	1.00 ± .10	2,500	10,000	N/A	N/A	N/A
FF	1210	1.10 ± .10	2,500	10,000	N/A	N/A	N/A
FG	1210	1.25 ± .15	2,500	10,000	N/A	N/A	N/A
FH	1210	1.55 ± .15	2,000	8,000	N/A	N/A	N/A
FJ	1210	1.85 ± .15	2,000	8,000	N/A	N/A	N/A
FK	1210	2.10 ± .20	2,000	8,000	N/A	N/A	N/A
GB	1812	1.00 ± .10	1,000	4,000	N/A	N/A	N/A
GC	1812	1.10 ± .10	1,000	4,000	N/A	N/A	N/A
GD	1812	1.25 ± .15	1,000	4,000	N/A	N/A	N/A
GE	1812	1.30 ± .10	1,000	4,000	N/A	N/A	N/A
GF	1812	1.50 ± .10	1,000	4,000	N/A	N/A	N/A
GG	1812	1.55 ± .10	1,000	4,000	N/A	N/A	N/A
GH	1812	1.40 ± .15	1,000	4,000	N/A	N/A	N/A
GJ	1812	1.70 ± .15	1,000	4,000	N/A	N/A	N/A
HB	1825	1.10 ± .15	1,000	4,000	N/A	N/A	N/A
HD	1825	1.30 ± .15	1,000	4,000	N/A	N/A	N/A
HE	1825	1.40 ± .15	1,000	4,000	N/A	N/A	N/A
HF	1825	1.50 ± .15	1,000	4,000	N/A	N/A	N/A
JB	2220	1.00 ± .15	1,000	4,000	N/A	N/A	N/A
JC	2220	1.10 ± .15	1,000	4,000	N/A	N/A	N/A
JD	2220	1.30 ± .15	1,000	4,000	N/A	N/A	N/A
JE	2220	1.40 ± .15	1,000	4,000	N/A	N/A	N/A
JF	2220	1.50 ± .15	1,000	4,000	N/A	N/A	N/A
KB	2225	1.00 ± .15	1,000	4,000	N/A	N/A	N/A
KC	2225	1.10 ± .15	1,000	4,000	N/A	N/A	N/A
KD	2225	1.30 ± .15	1,000	4,000	N/A	N/A	N/A
KE	2225	1.40 ± .15	1,000	4,000	N/A	N/A	N/A

This chart refers to ceramic chip thickness codes on pages 48-51.

FEATURES

- Four individual capacitors inside one 1206 monolithic structure
- Saves board and inventory space
- One placement instead of four - less costly
- Easier to handle and solder than 4 smaller chips
- Tape and reel per EIA 481-1

CAPACITOR OUTLINE DRAWING

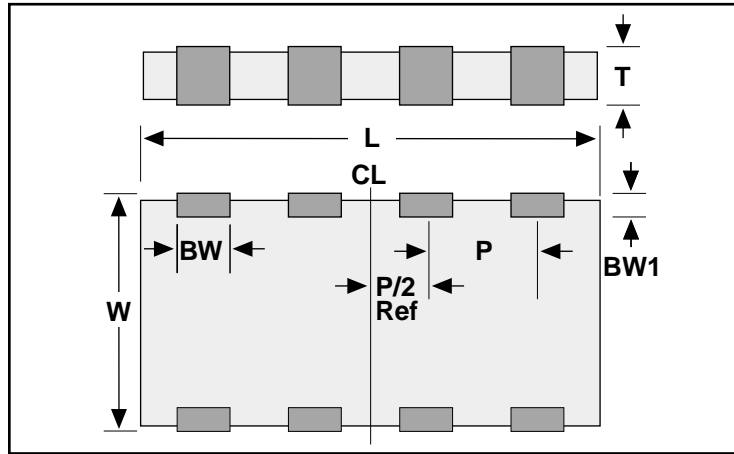

TABLE 1
EIA DIMENSIONS – MILLIMETERS (INCHES)

Size Code	Length L	Width W	Thickness T (max.)	Bandwidth BW	Bandwidth BW1	Pitch P
1632	3.2 (0.126) ± 0.2 (0.008)	1.6 (.063) ± 0.2 (.008)	0.7 - 1.35 (0.027 - 0.053)	0.40 (0.016) ± 0.2 (0.008)	0.1 - 0.5 (0.004 - 0.020)	0.8 (0.031) ± 0.1 (0.004)

Notes:

1. Metric is controlling - English for reference only.
2. Pitch (P) tolerances are non-cumulative along the package.
3. Thickness (T) depends on capacitance.

CERAMIC ARRAY ORDERING INFORMATION

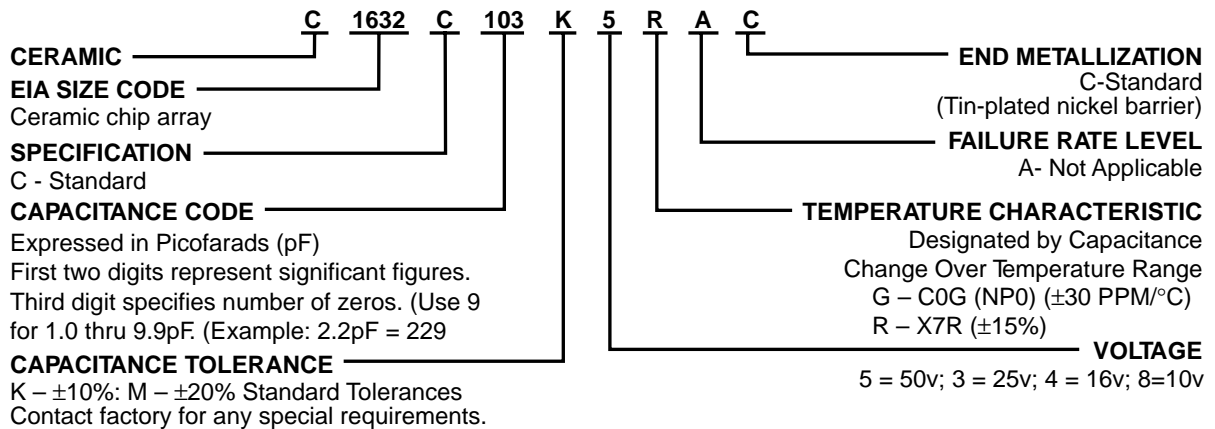

Ceramic Capacitor Array

TABLE 2A
COG DIELECTRIC – CAPACITANCE RANGE

Capacitance Values (pF)	KEMET Part Number	Capacitance Tolerance	10V 16V	25V	50V	100V	200V
10	C1632C100(1)(2)GAC	K,M	100	100	100	100	100
12	C1632C120(1)(2)GAC	K,M	120	120	120	120	120
15	C1632C150(1)(2)GAC	K,M	150	150	150	150	150
18	C1632C180(1)(2)GAC	K,M	180	180	180	180	180
22	C1632C220(1)(2)GAC	K,M	220	220	220	220	220
27	C1632C270(1)(2)GAC	K,M	270	270	270	270	270
33	C1632C330(1)(2)GAC	K,M	330	330	330	330	330
39	C1632C390(1)(2)GAC	K,M	390	390	390	390	390
47	C1632C470(1)(2)GAC	K,M	470	470	470	470	470
56	C1632C560(1)(2)GAC	K,M	560	560	560	560	560
68	C1632C680(1)(2)GAC	K,M	680	680	680	680	680
82	C1632C820(1)(2)GAC	K,M	820	820	820	820	820
100	C1632C101(1)(2)GAC	K,M	101	101	101	101	
120	C1632C121(1)(2)GAC	K,M	121	121	121	121	
150	C1632C151(1)(2)GAC	K,M	151	151	151	151	
180	C1632C181(1)(2)GAC	K,M	181	181	181	181	
220	C1632C221(1)(2)GAC	K,M	221	221	221	221	
270	C1632C271(1)(2)GAC	K,M	271	271	271	271	
330	C1632C331(1)(2)GAC	K,M	331	331	331	331	
390	C1632C391(1)(2)GAC	K,M	391	391	391	391	
470	C1632C471(1)(2)GAC	K,M	471	471	471	471	

- (1) To complete the KEMET part number, insert the alpha code for the tolerance desired.
K = ±10% and M = ±20% – standard tolerance. Contact factory for any special requirements.
(2) To complete the KEMET part number, insert appropriate number for voltage desired:
"5" = 50 volts, "3" = 25 volts, "4" = 16 volts, and "8" = 10 volts.

TABLE 2B
X7R DIELECTRIC – CAPACITANCE RANGE

Capacitance Values (pF)	KEMET Part Number	Capacitance Tolerance	10V 16V	25V	50V	100V	200V
330	C1632C331(1)(2)RAC	K,M	331	331	331	331	331
390	C1632C391(1)(2)RAC	K,M	391	391	391	391	391
470	C1632C471(1)(2)RAC	K,M	471	471	471	471	471
560	C1632C561(1)(2)RAC	K,M	561	561	561	561	561
680	C1632C681(1)(2)RAC	K,M	681	681	681	681	
820	C1632C821(1)(2)RAC	K,M	821	821	821	821	
1000	C1632C102(1)(2)RAC	K,M	102	102	102	102	
1200	C1632C122(1)(2)RAC	K,M	122	122	122	122	
1500	C1632C152(1)(2)RAC	K,M	152	152	152	152	
1800	C1632C182(1)(2)RAC	K,M	182	182	182	182	
2200	C1632C222(1)(2)RAC	K,M	222	222	222	222	
2700	C1632C272(1)(2)RAC	K,M	272	272	272	272	
3300	C1632C332(1)(2)RAC	K,M	332	332	332	332	
3900	C1632C392(1)(2)RAC	K,M	392	392	392	392	
4700	C1632C472(1)(2)RAC	K,M	472	472	472	472	
5600	C1632C562(1)(2)RAC	K,M	562	562	562	562	
6800	C1632C682(1)(2)RAC	K,M	682	682	682	682	
8200	C1632C822(1)(2)RAC	K,M	822	822	822	822	
10,000	C1632C103(1)(2)RAC	K,M	103	103	103	103	
12,000	C1632C123(1)(2)RAC	K,M	123	123	123	123	
15,000	C1632C153(1)(2)RAC	K,M	153	153	153	153	
18,000	C1632C183(1)(2)RAC	K,M	183	183	183	183	
22,000	C1632C223(1)(2)RAC	K,M	223	223	223	223	
27,000	C1632C273(1)(2)RAC	K,M	273				
33,000	C1632C333(1)(2)RAC	K,M	333				
39,000	C1632C393(1)(2)RAC	K,M	393				
47,000	C1632C473(1)(2)RAC	K,M	473				
56,000	C1632C563(1)(2)RAC	K,M	563				
68,000	C1632C683(1)(2)RAC	K,M	683				
82,000	C1632C823(1)(2)RAC	K,M	823				
100,000	C1632C104(1)(2)RAC	K,M	104				

- (1) To complete the KEMET part number, insert the alpha code for the tolerance desired:
K = ±10% and M = ±20% – standard tolerances. Contact factory for any special requirements.
(2) To complete the KEMET part number, insert appropriate number for voltage desired:
"5" = 50 volts, "3" = 25 volts, "4" = 16 volts, and "8" = 10 volts.

1632 CERAMIC ARRAY LAND PATTERN LAYOUT

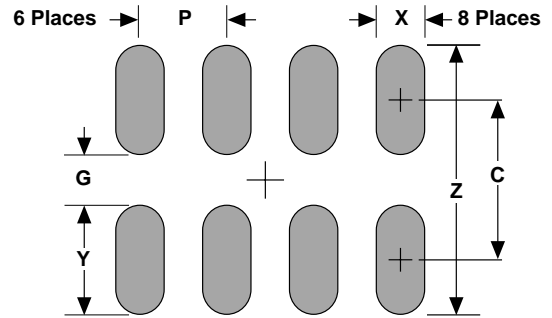

Additional pad dimension information is available in KEMET Technical Bulletin F-2100.

LAND PATTERN DIMENSIONS - CERAMIC CHIP CAPACITOR ARRAYS - MM

Dimension	Reflow Solder				
	Z	G	X	Y(ref)	C(ref)
3216	2.80	0.40	0.52	1.20	1.60

Calculation Formula
 $Z = L_{min} + 2J_t + T_t$
 $G = S_{max} - 2J_h - T_h$
 $X = W_{min} + 2J_s + T_s$
 $T_t, T_h, T_s = \text{Combined tolerances}$

CAPACITOR OUTLINE DRAWINGS

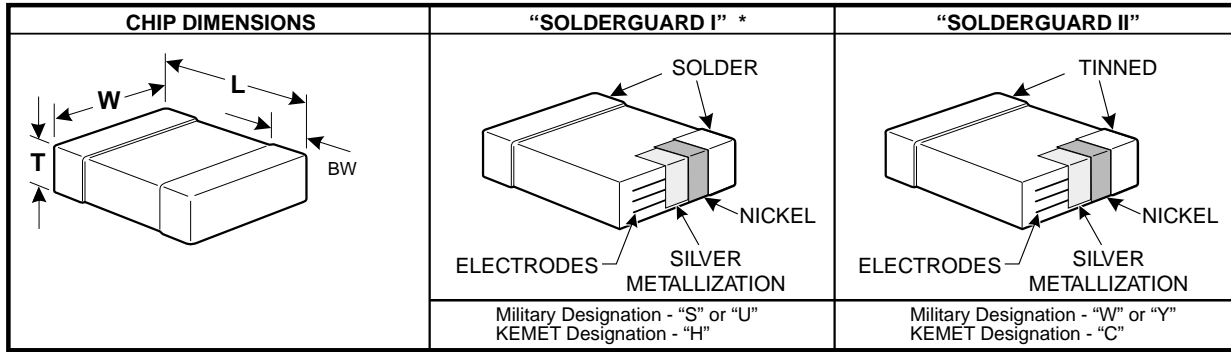

DIMENSIONS—MILLIMETERS AND (INCHES)

STYLE	KEMET SIZE CODE	L	W	T		BW
				MIN.	MAX.	
CDR01	C0805	2.03 ± .38 (.080 ± .015)	1.27 ± .38 (.050 ± .015)	.56 (.022)	1.40 (.055)	.51 ± 0.25 (.020 ± .010)
CDR02	C1805	4.57 ± .38 (.180 ± .015)	1.27 ± .38 (.050 ± .015)	.56 (.022)	1.40 (.055)	.51 ± 0.25 (.020 ± .010)
CDR03	C1808	4.57 ± .38 (.180 ± .015)	2.03 ± .38 (.080 ± .015)	.56 (.022)	2.03 (.080)	.51 ± 0.25 (.020 ± .010)
CDR04	C1812	4.57 ± .38 (.180 ± .015)	3.18 ± .38 (.125 ± .015)	.56 (.022)	2.03 (.080)	.51 ± 0.25 (.020 ± .010)
CDR05	C1825	4.57 $\left(\begin{smallmatrix} +.51 & +.020 \\ .180 & \\ -.38 & -.015 \end{smallmatrix} \right)$	6.35 $\left(\begin{smallmatrix} +.51 & +.020 \\ .250 & \\ -.38 & -.015 \end{smallmatrix} \right)$.51 (.020)	2.03 (.080)	.51 ± 0.25 (.020 ± .010)
CDR06	C2225	5.72 ± .51 (.225 ± .020)	6.35 ± .51 (.250 ± .020)	.51 (.020)	2.03 (.080)	.51 ± 0.25 (.020 ± .010)
CDR31	C0805	2.00 ± .20 (.078 ± .008)	1.25 ± .20 (.049 ± .008)		1.30 (.051)	.50 ± 0.20 (.020 ± .008)
CDR32	C1206	3.20 ± .20 (.125 ± .008)	1.60 ± .20 (.062 ± .008)		1.30 (.051)	.50 ± 0.20 (.020 ± .008)
CDR33	C1210	3.20 ± .25 (.125 ± .010)	2.50 ± .25 (.098 ± .010)		1.50 (.059)	.50 ± 0.25 (.020 ± .010)
CDR34	C1812	4.50 ± .25 (.176 ± .010)	3.20 ± .25 (.125 ± .010)		1.50 (.059)	.50 ± 0.25 (.020 ± .010)
CDR35	C1825	4.50 ± .30 (.176 ± .012)	6.40 ± .30 (.250 ± .012)		1.50 (.059)	.50 ± 0.30 (.020 ± .012)

Note: For Solderguard I (MIL-C55681 "S" or "U" Endmets), the length, width and thickness positive tolerances (including bandwidth) cited above are allowed to increase by the following amounts:

	Length	Width/Thickness
CDR01	0.51MM (.020)	0.38MM (.015)
CDR02-06	0.64MM (.025)	0.38MM (.015)
CDR31-35	0.60MM (.023)	0.30MM (.012)

MIL-PRF-55681 PART NUMBER ORDERING INFORMATION

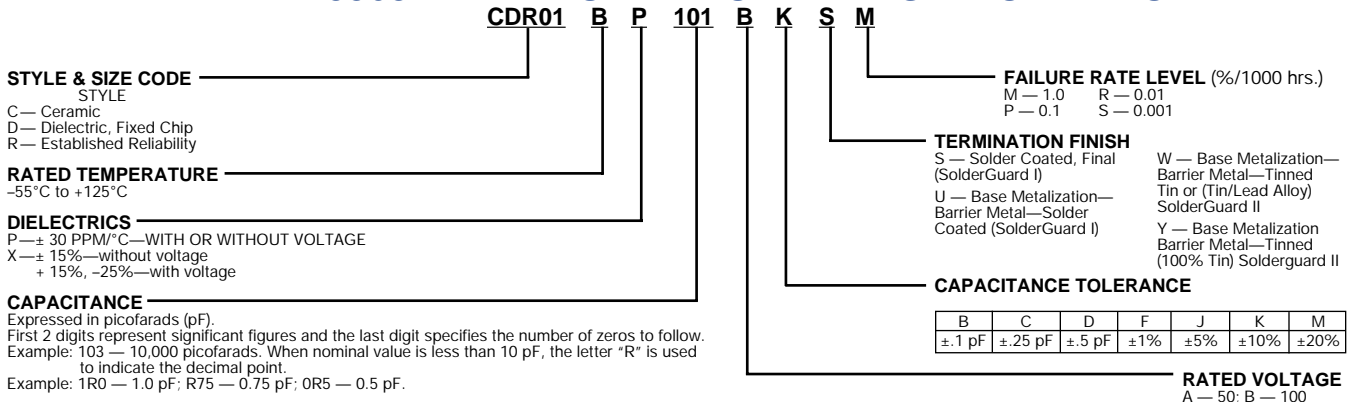

KEMET/MIL-PRF-55681 PART NUMBER EQUIVALENTS

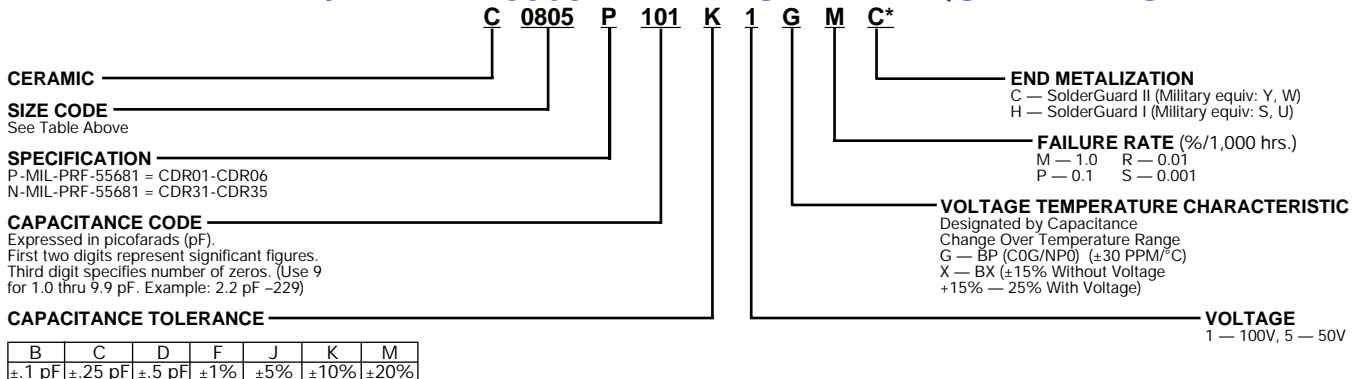

* Part Number Example: C0805P101K1GMC (14 digits - no spaces)

RATINGS & PART NUMBER REFERENCE

CHARACTERISTIC	CAP. pF	AVAIL. TOL.	KEMET CAPACITORS	MIL-PRF-55681 PART NUMBER	
100 Volt — C0805 SIZE (MILITARY CDR01)					
BP	10	J,K	C0805P100(3)1G(4)C	CDR01BP100B(3)W(4)	
	12	J	C0805P120J1G(4)C	CDR01BP120BJW(4)	
	15	J,K	C0805P150(3)1G(4)C	CDR01BP150B(3)W(4)	
	18	J	C0805P180J1G(4)C	CDR01BP180BJW(4)	
	22	J,K	C0805P220(3)1G(4)C	CDR01BP220B(3)W(4)	
	27	J	C0805P270J1G(4)C	CDR01BP270BJW(4)	
	33	J,K	C0805P330(3)1G(4)C	CDR01BP330B(3)W(4)	
	39	J	C0805P390J1G(4)C	CDR01BP390BJW(4)	
	47	J,K	C0805P470(3)1G(4)C	CDR01BP470B(3)W(4)	
	56	J	C0805P560J1G(4)C	CDR01BP560BJW(4)	
	68	J,K	C0805P680(3)1G(4)C	CDR01BP680B(3)W(4)	
	82	J	C0805P820J1G(4)C	CDR01BP820BJW(4)	
	100	J,K	C0805P101(3)1G(4)C	CDR01BP101B(3)W(4)	
	BP or BX	120	J,K	C0805P121(3)1(2)(4)C	CDR01B(1)121B(3)W(4)
		150	J,K	C0805P151(3)1(2)(4)C	CDR01B(1)151B(3)W(4)
180		J,K	C0805P181(3)1(2)(4)C	CDR01B(1)181B(3)W(4)	
BX	220	K,M	C0805P221(3)1X(4)C	CDR01BX221B(3)W(4)	
	270	K	C0805P271K1X(4)C	CDR01BX271BKW(4)	
	330	K,M	C0805P331(3)1X(4)C	CDR01BX331B(3)W(4)	
	390	K	C0805P391K1X(4)C	CDR01BX391BKW(4)	
	470	K,M	C0805P471(3)1X(4)C	CDR01BX471B(3)W(4)	
	560	K	C0805P561K1X(4)C	CDR01BX561BKW(4)	
	680	K,M	C0805P681(3)1X(4)C	CDR01BX681B(3)W(4)	
	820	K	C0805P821K1X(4)C	CDR01BX821BKW(4)	
	1,000	K,M	C0805P102(3)1X(4)C	CDR01BX102B(3)W(4)	
	1,200	K	C0805P122K1X(4)C	CDR01BX122BKW(4)	
	1,500	K,M	C0805P152(3)1X(4)C	CDR01BX152B(3)W(4)	
	1,800	K	C0805P182K1X(4)C	CDR01BX182BKW(4)	
	2,200	K,M	C0805P222(3)1X(4)C	CDR01BX222B(3)W(4)	
	2,700	K	C0805P272K1X(4)C	CDR01BX272BKW(4)	
	3,300	K,M	C0805P332(3)1X(4)C	CDR01BX332B(3)W(4)	
50 Volt — C0805 SIZE (MILITARY CDR01)					
BX	3,900	K	C0805P392K5X(4)C	CDR01BX392AKW(4)	
	4,700	K,M	C0805P472(3)5X(4)C	CDR01BX472A(3)W(4)	
100 Volt — C1805 SIZE (MILITARY CDR02)					
BP	220	J,K	C1805P221(3)1G(4)C	CDR02BP221B(3)W(4)	
	270	J	C1805P271J1G(4)C	CDR02BP271BJW(4)	
BX	3,900	K	C1805P392K1X(4)C	CDR02BX392BKW(4)	
	4,700	K,M	C1805P472(3)1X(4)C	CDR02BX472B(3)W(4)	
	5,600	K	C1805P562K1X(4)C	CDR02BX562BKW(4)	
	6,800	K,M	C1805P682(3)1X(4)C	CDR02BX682B(3)W(4)	
	8,200	K	C1805P822K1X(4)C	CDR02BX822BKW(4)	
	10,000	K,M	C1805P103(3)1X(4)C	CDR02BX103B(3)W(4)	
	50 Volt — C1805 SIZE (MILITARY CDR02)				
BX	12,000	K	C1805P123K5X(4)C	CDR02BX123AKW(4)	
	15,000	K,M	C1805P153(3)5X(4)C	CDR02BX153A(3)W(4)	
	18,000	K	C1805P183K5X(4)C	CDR02BX183AKW(4)	
	22,000	K,M	C1805P223(3)5X(4)C	CDR02BX223A(3)W(4)	
100 Volt — C1808 SIZE (MILITARY CDR03)					
BP	330	J,K	C1808P331(3)1G(4)C	CDR03BP331B(3)W(4)	
	390	J	C1808P391J1G(4)C	CDR03BP391BJW(4)	
	470	J,K	C1808P471(3)1G(4)C	CDR03BP471B(3)W(4)	

CHARACTERISTIC	CAP. pF	AVAIL. TOL.	KEMET CAPACITORS	MIL-PRF-55681 PART NUMBER
100 Volt — C1808 SIZE (MILITARY CDR03) (Cont'd)				
BP	560	J	C1808P561J1G(4)C	CDR03BP561BJW(4)
	680	J,K	C1808P681(3)1G(4)C	CDR03BP681B(3)W(4)
	820	J	C1808P821J1G(4)C	CDR03BP821BJW(4)
	1,000	J,K	C1808P102(3)1G(4)C	CDR03BP102B(3)W(4)
BX	12,000	K	C1808P123K1X(4)C	CDR03BX123BKW(4)
	15,000	K,M	C1808P153(3)1X(4)C	CDR03BX153B(3)W(4)
	18,000	K	C1808P183K1X(4)C	CDR03BX183BKW(4)
	22,000	K,M	C1808P223(3)1X(4)C	CDR03BX223B(3)W(4)
	27,000	K	C1808P273K1X(4)C	CDR03BX273BKW(4)
	33,000	K,M	C1808P333(3)1X(4)C	CDR03BX333B(3)W(4)
50 Volt — C1808 SIZE (MILITARY CDR03)				
BX	39,000	K	C1808P393K5X(4)C	CDR03BX393AKW(4)
	47,000	K,M	C1808P473(3)5X(4)C	CDR03BX473A(3)W(4)
	56,000	K	C1808P563K5X(4)C	CDR03BX563AKW(4)
	68,000	K,M	C1808P683(3)5X(4)C	CDR03BX683A(3)W(4)
100 Volt — C1812 SIZE (MILITARY CDR04)				
BP	1,200	J	C1812P122J1G(4)C	CDR04BP122BJW(4)
	1,500	J,K	C1812P152(3)1G(4)C	CDR04BP152B(3)W(4)
	1,800	J	C1812P182J1G(4)C	CDR04BP182BJW(4)
	2,200	J,K	C1812P222(3)1G(4)C	CDR04BP222B(3)W(4)
	2,700	J	C1812P272J1G(4)C	CDR04BP272BJW(4)
	3,300	J,K	C1812P332(3)1G(4)C	CDR04BP332B(3)W(4)
BX	39,000	K	C1812P393K1X(4)C	CDR04BX393BKW(4)
	47,000	K,M	C1812P473(3)1X(4)C	CDR04BX473B(3)W(4)
	56,000	K	C1812P563K1X(4)C	CDR04BX563BKW(4)
	50 Volt — C1812 SIZE (MILITARY CDR04)			
BX	82,000	K	C1812P823K5X(4)C	CDR04BX823AKW(4)
	100,000	K,M	C1812P104(3)5X(4)C	CDR04BX104A(3)W(4)
	120,000	K	C1812P124K5X(4)C	CDR04BX124AKW(4)
	150,000	K,M	C1812P154(3)5X(4)C	CDR04BX154A(3)W(4)
	180,000	K	C1812P184K5X(4)C	CDR04BX184AKW(4)
100 Volt — C1825 SIZE (MILITARY CDR05)				
BP	3,900	J,K	C1825P392(3)1G(4)C	CDR05BP392B(3)W(4)
	4,700	J,K	C1825P472(3)1G(4)C	CDR05BP472B(3)W(4)
	5,600	J,K	C1825P562(3)1G(4)C	CDR05BP562B(3)W(4)
BX	68,000	K,M	C1825P683(3)1X(4)C	CDR05BX683B(3)W(4)
	82,000	K	C1825P823K1X(4)C	CDR05BX823BKW(4)
	100,000	K,M	C1825P104(3)1X(4)C	CDR05BX104B(3)W(4)
	120,000	K	C1825P124K1X(4)C	CDR05BX124BKW(4)
	150,000	K,M	C1825P154(3)1X(4)C	CDR05BX154B(3)W(4)
50 Volt — C1825 SIZE (MILITARY CDR05)				
BX	220,000	K,M	C1825P224(3)5X(4)C	CDR05BX224A(3)W(4)
	270,000	K	C1825P274K5X(4)C	CDR05BX274AKW(4)
	330,000	K,M	C1825P334(3)5X(4)C	CDR05BX334A(3)W(4)
100 Volt — C2225 SIZE (MILITARY CDR06)				
BP	6,800	J,K	C2225P682(3)1G(4)C	CDR06BP682B(3)W(4)
	8,200	J,K	C2225P822(3)1G(4)C	CDR06BP822B(3)W(4)
	10,000	J,K	C2225P103(3)1G(4)C	CDR06BP103B(3)W(4)
50 Volt — C2225 SIZE (MILITARY CDR06)				
BX	390,000	K	C2225P394K5X(4)C	CDR06BX394AKW(4)
	470,000	K,M	C2225P474(3)5X(4)C	CDR06BX474A(3)W(4)

- To complete Part Number for Dielectric, insert P or X symbol – as defined by Military specification.
- To complete Part Number for Dielectric, insert G or X symbol. ("G" for Military "BP," or "X" for Military "BX.")
- To complete Part Number, insert Capacitance Tolerance Symbol (when applicable) as available in MIL-PRF-55681: B – ±0.1 pF, C – ±0.25 pF, D – ±0.5pF, F – ±1%, J – ±5%, K – ±10%, M – ±20%. **NOTE: Available tolerances are listed in columns above.**
- To complete Part Number, insert Failure Rate Symbol: M –1.0%; P –0.1%; R –0.01%; S –.001%.

Note: All MIL-PRF-55681 and KEMET Part Numbers tabulated above assume use of Solderguard II (MIL-PRF-55681 "W"; KEMET "C") end metalization. If MIL-PRF-55681 "U" or "S" (KEMET "H") or MIL-PRF-55681 "Y" (KEMET "C") is required, please change designators accordingly.

RATINGS & PART NUMBER REFERENCE

CAP. pF	AVAIL. TOL.	KEMET CAPACITORS	MIL-PRF-55681 PART NUMBER
100 Volt — BP — C0805 SIZE (MILITARY CDR31)			
1.0	B,C	C0805N109(3)1G(4)C	CDR31BP1R0B(3)W(4)
1.1	B,C	C0805N119(3)1G(4)C	CDR31BP1R1B(3)W(4)
1.2	B,C	C0805N129(3)1G(4)C	CDR31BP1R2B(3)W(4)
1.3	B,C	C0805N139(3)1G(4)C	CDR31BP1R3B(3)W(4)
1.5	B,C	C0805N159(3)1G(4)C	CDR31BP1R5B(3)W(4)
1.6	B,C	C0805N169(3)1G(4)C	CDR31BP1R6B(3)W(4)
1.8	B,C	C0805N189(3)1G(4)C	CDR31BP1R8B(3)W(4)
2.0	B,C	C0805N209(3)1G(4)C	CDR31BP2R0B(3)W(4)
2.2	B,C	C0805N229(3)1G(4)C	CDR31BP2R2B(3)W(4)
2.4	B,C	C0805N249(3)1G(4)C	CDR31BP2R4B(3)W(4)
2.7	B,C,D	C0805N279(3)1G(4)C	CDR31BP2R7B(3)W(4)
3.0	B,C,D	C0805N309(3)1G(4)C	CDR31BP3R0B(3)W(4)
3.3	B,C,D	C0805N339(3)1G(4)C	CDR31BP3R3B(3)W(4)
3.6	B,C,D	C0805N369(3)1G(4)C	CDR31BP3R6B(3)W(4)
3.9	B,C,D	C0805N399(3)1G(4)C	CDR31BP3R9B(3)W(4)
4.3	B,C,D	C0805N439(3)1G(4)C	CDR31BP4R3B(3)W(4)
4.7	B,C,D	C0805N479(3)1G(4)C	CDR31BP4R7B(3)W(4)
5.1	B,C,D	C0805N519(3)1G(4)C	CDR31BP5R1B(3)W(4)
5.6	B,C,D	C0805N569(3)1G(4)C	CDR31BP5R6B(3)W(4)
6.2	B,C,D	C0805N629(3)1G(4)C	CDR31BP6R2B(3)W(4)
6.8	B,C,D	C0805N689(3)1G(4)C	CDR31BP6R8B(3)W(4)
7.5	B,C,D	C0805N759(3)1G(4)C	CDR31BP7R5B(3)W(4)
8.2	B,C,D	C0805N829(3)1G(4)C	CDR31BP8R2B(3)W(4)
9.1	B,C,D	C0805N919(3)1G(4)C	CDR31BP9R1B(3)W(4)
10	F,J,K	C0805N100(3)1G(4)C	CDR31BP100B(3)W(4)
11	F,J,K	C0805N110(3)1G(4)C	CDR31BP110B(3)W(4)
12	F,J,K	C0805N120(3)1G(4)C	CDR31BP120B(3)W(4)
13	F,J,K	C0805N130(3)1G(4)C	CDR31BP130B(3)W(4)
15	F,J,K	C0805N150(3)1G(4)C	CDR31BP150B(3)W(4)
16	F,J,K	C0805N160(3)1G(4)C	CDR31BP160B(3)W(4)
18	F,J,K	C0805N180(3)1G(4)C	CDR31BP180B(3)W(4)
20	F,J,K	C0805N200(3)1G(4)C	CDR31BP200B(3)W(4)
22	F,J,K	C0805N220(3)1G(4)C	CDR31BP220B(3)W(4)
24	F,J,K	C0805N240(3)1G(4)C	CDR31BP240B(3)W(4)
27	F,J,K	C0805N270(3)1G(4)C	CDR31BP270B(3)W(4)
30	F,J,K	C0805N300(3)1G(4)C	CDR31BP300B(3)W(4)
33	F,J,K	C0805N330(3)1G(4)C	CDR31BP330B(3)W(4)
36	F,J,K	C0805N360(3)1G(4)C	CDR31BP360B(3)W(4)
39	F,J,K	C0805N390(3)1G(4)C	CDR31BP390B(3)W(4)
43	F,J,K	C0805N430(3)1G(4)C	CDR31BP430B(3)W(4)
47	F,J,K	C0805N470(3)1G(4)C	CDR31BP470B(3)W(4)
51	F,J,K	C0805N510(3)1G(4)C	CDR31BP510B(3)W(4)
56	F,J,K	C0805N560(3)1G(4)C	CDR31BP560B(3)W(4)
62	F,J,K	C0805N620(3)1G(4)C	CDR31BP620B(3)W(4)
68	F,J,K	C0805N680(3)1G(4)C	CDR31BP680B(3)W(4)
75	F,J,K	C0805N750(3)1G(4)C	CDR31BP750B(3)W(4)
82	F,J,K	C0805N820(3)1G(4)C	CDR31BP820B(3)W(4)

CAP. pF	AVAIL. TOL.	KEMET CAPACITORS	MIL-PRF-55681 PART NUMBER
100 Volt — BP — C0805 SIZE (MILITARY CDR31)			
91	F,J,K	C0805N910(3)1G(4)C	CDR31BP910B(3)W(4)
100	F,J,K	C0805N101(3)1G(4)C	CDR31BP101B(3)W(4)
110	F,J,K	C0805N111(3)1G(4)C	CDR31BP111B(3)W(4)
120	F,J,K	C0805N121(3)1G(4)C	CDR31BP121B(3)W(4)
130	F,J,K	C0805N131(3)1G(4)C	CDR31BP131B(3)W(4)
150	F,J,K	C0805N151(3)1G(4)C	CDR31BP151B(3)W(4)
160	F,J,K	C0805N161(3)1G(4)C	CDR31BP161B(3)W(4)
180	F,J,K	C0805N181(3)1G(4)C	CDR31BP181B(3)W(4)
200	F,J,K	C0805N201(3)1G(4)C	CDR31BP201B(3)W(4)
220	F,J,K	C0805N221(3)1G(4)C	CDR31BP221B(3)W(4)
240	F,J,K	C0805N241(3)1G(4)C	CDR31BP241B(3)W(4)
270	F,J,K	C0805N271(3)1G(4)C	CDR31BP271B(3)W(4)
300	F,J,K	C0805N301(3)1G(4)C	CDR31BP301B(3)W(4)
330	F,J,K	C0805N331(3)1G(4)C	CDR31BP331B(3)W(4)
360	F,J,K	C0805N361(3)1G(4)C	CDR31BP361B(3)W(4)
390	F,J,K	C0805N391(3)1G(4)C	CDR31BP391B(3)W(4)
430	F,J,K	C0805N431(3)1G(4)C	CDR31BP431B(3)W(4)
470	F,J,K	C0805N471(3)1G(4)C	CDR31BP471B(3)W(4)
50 Volt — BP — C0805 SIZE (MILITARY CDR31)			
510	F,J,K	C0805N511(3)5G(4)C	CDR31BP511A(3)W(4)
560	F,J,K	C0805N561(3)5G(4)C	CDR31BP561A(3)W(4)
620	F,J,K	C0805N621(3)5G(4)C	CDR31BP621A(3)W(4)
680	F,J,K	C0805N681(3)5G(4)C	CDR31BP681A(3)W(4)
100 Volt — BX — C0805 SIZE (MILITARY CDR31)			
470	K,M	C0805N471(3)1X(4)C	CDR31BX471B(3)W(4)
560	K,M	C0805N561(3)1X(4)C	CDR31BX561B(3)W(4)
680	K,M	C0805N681(3)1X(4)C	CDR31BX681B(3)W(4)
820	K,M	C0805N821(3)1X(4)C	CDR31BX821B(3)W(4)
1,000	K,M	C0805N102(3)1X(4)C	CDR31BX102B(3)W(4)
1,200	K,M	C0805N122(3)1X(4)C	CDR31BX122B(3)W(4)
1,500	K,M	C0805N152(3)1X(4)C	CDR31BX152B(3)W(4)
1,800	K,M	C0805N182(3)1X(4)C	CDR31BX182B(3)W(4)
2,200	K,M	C0805N222(3)1X(4)C	CDR31BX222B(3)W(4)
2,700	K,M	C0805N272(3)1X(4)C	CDR31BX272B(3)W(4)
3,300	K,M	C0805N332(3)1X(4)C	CDR31BX332B(3)W(4)
3,900	K,M	C0805N392(3)1X(4)C	CDR31BX392B(3)W(4)
4,700	K,M	C0805N472(3)1X(4)C	CDR31BX472B(3)W(4)
50 Volt — BX — C0805 SIZE (MILITARY CDR31)			
5,600	K,M	C0805N562(3)5X(4)C	CDR31BX562A(3)W(4)
6,800	K,M	C0805N682(3)5X(4)C	CDR31BX682A(3)W(4)
8,200	K,M	C0805N822(3)5X(4)C	CDR31BX822A(3)W(4)
10,000	K,M	C0805N103(3)5X(4)C	CDR31BX103A(3)W(4)
12,000	K,M	C0805N123(3)5X(4)C	CDR31BX123A(3)W(4)
15,000	K,M	C0805N153(3)5X(4)C	CDR31BX153A(3)W(4)
18,000	K,M	C0805N183(3)5X(4)C	CDR31BX183A(3)W(4)

- (1) To complete Part Number for Dielectric, insert P or X symbol – as defined by Military specification.
- (2) To complete Part Number for Dielectric, insert G or X symbol. (“G” for Military “BP,” or “X” for Military “BX.”)
- (3) To complete Part Number, insert Capacitance Tolerance Symbol (when applicable) as available in MIL-PRF-55681: B – ±0.1 pF, C – ±0.25 pF, D – ±0.5pF, F – ±1%, J – ±5%, K – ±10%, M – ±20%. **NOTE: Available tolerances are listed in columns above.**
- (4) To complete Part Number, insert Failure Rate Symbol: M –1.0%; P –0.1%; R –0.01%; S –.001%.

Note: All MIL-PRF-55681 and KEMET Part Numbers tabulated above assume use of Solderguard II (MIL-PRF-55681 “W”; KEMET “C”) end metal-ization. If MIL-PRF-55681 “U” or “S” (KEMET “H”) or MIL-PRF-55681 “Y” (KEMET “C”) is required, please change designators accordingly.

MARKING

See page 65 for MIL-PRF-55681 Marking

RATINGS & PART NUMBER REFERENCE

CAP. pF	AVAIL. TOL.	KEMET CAPACITORS	MIL-PRF-55681 PART NUMBER
100 Volt — BP — C1206 SIZE (MILITARY CDR32)			
1.0	B,C	C1206N109(3)1G(4)C	CDR32BP1R0B(3)W(4)
1.1	B,C	C1206N119(3)1G(4)C	CDR32BP1R1B(3)W(4)
1.2	B,C	C1206N129(3)1G(4)C	CDR32BP1R2B(3)W(4)
1.3	B,C	C1206N139(3)1G(4)C	CDR32BP1R3B(3)W(4)
1.5	B,C	C1206N159(3)1G(4)C	CDR32BP1R5B(3)W(4)
1.6	B,C	C1206N169(3)1G(4)C	CDR32BP1R6B(3)W(4)
1.8	B,C	C1206N189(3)1G(4)C	CDR32BP1R8B(3)W(4)
2.0	B,C	C1206N209(3)1G(4)C	CDR32BP2R0B(3)W(4)
2.2	B,C	C1206N229(3)1G(4)C	CDR32BP2R2B(3)W(4)
2.4	B,C	C1206N249(3)1G(4)C	CDR32BP2R4B(3)W(4)
2.7	B,C,D	C1206N279(3)1G(4)C	CDR32BP2R7B(3)W(4)
3.0	B,C,D	C1206N309(3)1G(4)C	CDR32BP3R0B(3)W(4)
3.3	B,C,D	C1206N339(3)1G(4)C	CDR32BP3R3B(3)W(4)
3.6	B,C,D	C1206N369(3)1G(4)C	CDR32BP3R6B(3)W(4)
3.9	B,C,D	C1206N399(3)1G(4)C	CDR32BP3R9B(3)W(4)
4.3	B,C,D	C1206N439(3)1G(4)C	CDR32BP4R3B(3)W(4)
4.7	B,C,D	C1206N479(3)1G(4)C	CDR32BP4R7B(3)W(4)
5.1	B,C,D	C1206N519(3)1G(4)C	CDR32BP5R1B(3)W(4)
5.6	B,C,D	C1206N569(3)1G(4)C	CDR32BP5R6B(3)W(4)
6.2	B,C,D	C1206N629(3)1G(4)C	CDR32BP6R2B(3)W(4)
6.8	B,C,D	C1206N689(3)1G(4)C	CDR32BP6R8B(3)W(4)
7.5	B,C,D	C1206N759(3)1G(4)C	CDR32BP7R5B(3)W(4)
8.2	B,C,D	C1206N829(3)1G(4)C	CDR32BP8R2B(3)W(4)
9.1	B,C,D	C1206N919(3)1G(4)C	CDR32BP9R1B(3)W(4)
10	F,J,K	C1206N100(3)1G(4)C	CDR32BP100B(3)W(4)
11	F,J,K	C1206N110(3)1G(4)C	CDR32BP110B(3)W(4)
12	F,J,K	C1206N120(3)1G(4)C	CDR32BP120B(3)W(4)
13	F,J,K	C1206N130(3)1G(4)C	CDR32BP130B(3)W(4)
15	F,J,K	C1206N150(3)1G(4)C	CDR32BP150B(3)W(4)
16	F,J,K	C1206N160(3)1G(4)C	CDR32BP160B(3)W(4)
18	F,J,K	C1206N180(3)1G(4)C	CDR32BP180B(3)W(4)
20	F,J,K	C1206N200(3)1G(4)C	CDR32BP200B(3)W(4)
22	F,J,K	C1206N220(3)1G(4)C	CDR32BP220B(3)W(4)
24	F,J,K	C1206N240(3)1G(4)C	CDR32BP240B(3)W(4)
27	F,J,K	C1206N270(3)1G(4)C	CDR32BP270B(3)W(4)
30	F,J,K	C1206N300(3)1G(4)C	CDR32BP300B(3)W(4)
33	F,J,K	C1206N330(3)1G(4)C	CDR32BP330B(3)W(4)
36	F,J,K	C1206N360(3)1G(4)C	CDR32BP360B(3)W(4)
39	F,J,K	C1206N390(3)1G(4)C	CDR32BP390B(3)W(4)
43	F,J,K	C1206N430(3)1G(4)C	CDR32BP430B(3)W(4)
47	F,J,K	C1206N470(3)1G(4)C	CDR32BP470B(3)W(4)
51	F,J,K	C1206N510(3)1G(4)C	CDR32BP510B(3)W(4)
56	F,J,K	C1206N560(3)1G(4)C	CDR32BP560B(3)W(4)
62	F,J,K	C1206N620(3)1G(4)C	CDR32BP620B(3)W(4)
68	F,J,K	C1206N680(3)1G(4)C	CDR32BP680B(3)W(4)
75	F,J,K	C1206N750(3)1G(4)C	CDR32BP750B(3)W(4)
82	F,J,K	C1206N820(3)1G(4)C	CDR32BP820B(3)W(4)
91	F,J,K	C1206N910(3)1G(4)C	CDR32BP910B(3)W(4)
100	F,J,K	C1206N101(3)1G(4)C	CDR32BP101B(3)W(4)

CAP. pF	AVAIL. TOL.	KEMET CAPACITORS	MIL-PRF-55681 PART NUMBER
100 Volt — BP — C1206 SIZE (MILITARY CDR32)			
110	F,J,K	C1206N111(3)1G(4)C	CDR32BP111B(3)W(4)
120	F,J,K	C1206N121(3)1G(4)C	CDR32BP121B(3)W(4)
130	F,J,K	C1206N131(3)1G(4)C	CDR32BP131B(3)W(4)
150	F,J,K	C1206N151(3)1G(4)C	CDR32BP151B(3)W(4)
160	F,J,K	C1206N161(3)1G(4)C	CDR32BP161B(3)W(4)
180	F,J,K	C1206N181(3)1G(4)C	CDR32BP181B(3)W(4)
200	F,J,K	C1206N201(3)1G(4)C	CDR32BP201B(3)W(4)
220	F,J,K	C1206N221(3)1G(4)C	CDR32BP221B(3)W(4)
240	F,J,K	C1206N241(3)1G(4)C	CDR32BP241B(3)W(4)
270	F,J,K	C1206N271(3)1G(4)C	CDR32BP271B(3)W(4)
300	F,J,K	C1206N301(3)1G(4)C	CDR32BP301B(3)W(4)
330	F,J,K	C1206N331(3)1G(4)C	CDR32BP331B(3)W(4)
360	F,J,K	C1206N361(3)1G(4)C	CDR32BP361B(3)W(4)
390	F,J,K	C1206N391(3)1G(4)C	CDR32BP391B(3)W(4)
430	F,J,K	C1206N431(3)1G(4)C	CDR32BP431B(3)W(4)
470	F,J,K	C1206N471(3)1G(4)C	CDR32BP471B(3)W(4)
510	F,J,K	C1206N511(3)1G(4)C	CDR32BP511B(3)W(4)
560	F,J,K	C1206N561(3)1G(4)C	CDR32BP561B(3)W(4)
620	F,J,K	C1206N621(3)1G(4)C	CDR32BP621B(3)W(4)
680	F,J,K	C1206N681(3)1G(4)C	CDR32BP681B(3)W(4)
750	F,J,K	C1206N751(3)1G(4)C	CDR32BP751B(3)W(4)
820	F,J,K	C1206N821(3)1G(4)C	CDR32BP821B(3)W(4)
910	F,J,K	C1206N911(3)1G(4)C	CDR32BP911B(3)W(4)
1,000	F,J,K	C1206N102(3)1G(4)C	CDR32BP102B(3)W(4)
50 Volt — BP — C1206 SIZE (MILITARY CDR32)			
1,100	F,J,K	C1206N112(3)5G(4)C	CDR32BP112A(3)W(4)
1,200	F,J,K	C1206N122(3)5G(4)C	CDR32BP122A(3)W(4)
1,300	F,J,K	C1206N132(3)5G(4)C	CDR32BP132A(3)W(4)
1,500	F,J,K	C1206N152(3)5G(4)C	CDR32BP152A(3)W(4)
1,600	F,J,K	C1206N162(3)5G(4)C	CDR32BP162A(3)W(4)
1,800	F,J,K	C1206N182(3)5G(4)C	CDR32BP182A(3)W(4)
2,000	F,J,K	C1206N202(3)5G(4)C	CDR32BP202A(3)W(4)
2,200	F,J,K	C1206N222(3)5G(4)C	CDR32BP222A(3)W(4)
100 Volt — BX — C1206 SIZE (MILITARY CDR32)			
4,700	K,M	C1206N472(3)1X(4)C	CDR32BX472B(3)W(4)
5,600	K,M	C1206N562(3)1X(4)C	CDR32BX562B(3)W(4)
6,800	K,M	C1206N682(3)1X(4)C	CDR32BX682B(3)W(4)
8,200	K,M	C1206N822(3)1X(4)C	CDR32BX822B(3)W(4)
10,000	K,M	C1206N103(3)1X(4)C	CDR32BX103B(3)W(4)
12,000	K,M	C1206N123(3)1X(4)C	CDR32BX123B(3)W(4)
15,000	K,M	C1206N153(3)1X(4)C	CDR32BX153B(3)W(4)
50 Volt — BX — C1206 SIZE (MILITARY CDR32)			
18,000	K,M	C1206N183(3)5X(4)C	CDR32BX183A(3)W(4)
22,000	K,M	C1206N223(3)5X(4)C	CDR32BX223A(3)W(4)
27,000	K,M	C1206N273(3)5X(4)C	CDR32BX273A(3)W(4)
33,000	K,M	C1206N333(3)5X(4)C	CDR32BX333A(3)W(4)
39,000	K,M	C1206N393(3)5X(4)C	CDR32BX393A(3)W(4)

- To complete Part Number for Dielectric, insert P or X symbol – as defined by Military specification.
- To complete Part Number for Dielectric, insert G or X symbol. (“G” for Military “BP,” or “X” for Military “BX.”)
- To complete Part Number, insert Capacitance Tolerance Symbol (when applicable) as available in MIL-PRF-55681: B – ±0.1 pF, C – ±0.25 pF, D – ±0.5pF, F – ±1%, J – ±5%, K – ±10%, M – ±20%. **NOTE: Available tolerances are listed in columns above.**
- To complete Part Number, insert Failure Rate Symbol: M –1.0%; P –0.1%; R –0.01%; S –.001%.

Note: All MIL-PRF-55681 and KEMET Part Numbers tabulated above assume use of Solderguard II (MIL-PRF-55681 “W”; KEMET “C”) end metalization. If MIL-PRF-55681 “U” or “S” (KEMET “H”) or MIL-PRF-55681 “Y” (KEMET “C”) is required, please change designators accordingly.

RATINGS & PART NUMBER REFERENCE

CAP. pF	AVAIL. TOL.	KEMET CAPACITORS	MIL-PRF-55681 PART NUMBER
100 Volt — BP — C1210 SIZE (MILITARY CDR33)			
1,000	F,J,K	C1210N102(3)1G(4)C	CDR33BP102B(3)W(4)
1,100	F,J,K	C1210N112(3)1G(4)C	CDR33BP112B(3)W(4)
1,200	F,J,K	C1210N122(3)1G(4)C	CDR33BP122B(3)W(4)
1,300	F,J,K	C1210N132(3)1G(4)C	CDR33BP132B(3)W(4)
1,500	F,J,K	C1210N152(3)1G(4)C	CDR33BP152B(3)W(4)
1,600	F,J,K	C1210N162(3)1G(4)C	CDR33BP162B(3)W(4)
1,800	F,J,K	C1210N182(3)1G(4)C	CDR33BP182B(3)W(4)
2,000	F,J,K	C1210N202(3)1G(4)C	CDR33BP202B(3)W(4)
2,200	F,J,K	C1210N222(3)1G(4)C	CDR33BP222B(3)W(4)
50 Volt — BP — C1210 SIZE (MILITARY CDR33)			
2,400	F,J,K	C1210N242(3)5G(4)C	CDR33BP242A(3)W(4)
2,700	F,J,K	C1210N272(3)5G(4)C	CDR33BP272A(3)W(4)
3,000	F,J,K	C1210N302(3)5G(4)C	CDR33BP302A(3)W(4)
3,300	F,J,K	C1210N332(3)5G(4)C	CDR33BP332A(3)W(4)
100 Volt — BX — C1210 SIZE (MILITARY CDR33)			
15,000	K,M	C1210N153(3)1X(4)C	CDR33BX153B(3)W(4)
18,000	K,M	C1210N183(3)1X(4)C	CDR33BX183B(3)W(4)
22,000	K,M	C1210N223(3)1X(4)C	CDR33BX223B(3)W(4)
27,000	K,M	C1210N273(3)1X(4)C	CDR33BX273B(3)W(4)
50 Volt — BX — C1210 SIZE (MILITARY CDR33)			
39,000	K,M	C1210N393(3)5X(4)C	CDR33BX393A(3)W(4)
47,000	K,M	C1210N473(3)5X(4)C	CDR33BX473A(3)W(4)
56,000	K,M	C1210N563(3)5X(4)C	CDR33BX563A(3)W(4)
68,000	K,M	C1210N683(3)5X(4)C	CDR33BX683A(3)W(4)
82,000	K,M	C1210N823(3)5X(4)C	CDR33BX823A(3)W(4)
100,000	K,M	C1210N104(3)5X(4)C	CDR33BX104A(3)W(4)
100 Volt — BP — C1812 SIZE (MILITARY CDR34)			
2,200	F,J,K	C1812N222(3)1G(4)C	CDR34BP222B(3)W(4)
2,400	F,J,K	C1812N242(3)1G(4)C	CDR34BP242B(3)W(4)
2,700	F,J,K	C1812N272(3)1G(4)C	CDR34BP272B(3)W(4)
3,000	F,J,K	C1812N302(3)1G(4)C	CDR34BP302B(3)W(4)
3,300	F,J,K	C1812N332(3)1G(4)C	CDR34BP332B(3)W(4)
3,600	F,J,K	C1812N362(3)1G(4)C	CDR34BP362B(3)W(4)
3,900	F,J,K	C1812N392(3)1G(4)C	CDR34BP392B(3)W(4)
4,300	F,J,K	C1812N432(3)1G(4)C	CDR34BP432B(3)W(4)
4,700	F,J,K	C1812N472(3)1G(4)C	CDR34BP472B(3)W(4)
50 Volt — BP — C1812 SIZE (MILITARY CDR34)			
5,100	F,J,K	C1812N512(3)5G(4)C	CDR34BP512A(3)W(4)
5,600	F,J,K	C1812N562(3)5G(4)C	CDR34BP562A(3)W(4)
6,200	F,J,K	C1812N622(3)5G(4)C	CDR34BP622A(3)W(4)
6,800	F,J,K	C1812N682(3)5G(4)C	CDR34BP682A(3)W(4)
7,500	F,J,K	C1812N752(3)5G(4)C	CDR34BP752A(3)W(4)
8,200	F,J,K	C1812N822(3)5G(4)C	CDR34BP822A(3)W(4)
9,100	F,J,K	C1812N912(3)5G(4)C	CDR34BP912A(3)W(4)
10,000	F,J,K	C1812N103(3)5G(4)C	CDR34BP103A(3)W(4)

CAP. pF	AVAIL. TOL.	KEMET CAPACITORS	MIL-PRF-55681 PART NUMBER
100 Volt — BX — C1812 SIZE (MILITARY CDR34)			
27,000	K,M	C1812N273(3)1X(4)C	CDR34BX273B(3)W(4)
33,000	K,M	C1812N333(3)1X(4)C	CDR34BX333B(3)W(4)
39,000	K,M	C1812N393(3)1X(4)C	CDR34BX393B(3)W(4)
47,000	K,M	C1812N473(3)1X(4)C	CDR34BX473B(3)W(4)
56,000	K,M	C1812N563(3)1X(4)C	CDR34BX563B(3)W(4)
50 Volt — BX — C1812 SIZE (MILITARY CDR34)			
100,000	K,M	C1812N104(3)5X(4)C	CDR34BX104A(3)W(4)
120,000	K,M	C1812N124(3)5X(4)C	CDR34BX124A(3)W(4)
150,000	K,M	C1812N154(3)5X(4)C	CDR34BX154A(3)W(4)
180,000	K,M	C1812N184(3)5X(4)C	CDR34BX184A(3)W(4)
100 Volt — BP — C1825 SIZE (MILITARY CDR35)			
4,700	F,J,K	C1825N472(3)1G(4)C	CDR35BP472B(3)W(4)
5,100	F,J,K	C1825N512(3)1G(4)C	CDR35BP512B(3)W(4)
5,600	F,J,K	C1825N562(3)1G(4)C	CDR35BP562B(3)W(4)
6,200	F,J,K	C1825N622(3)1G(4)C	CDR35BP622B(3)W(4)
6,800	F,J,K	C1825N682(3)1G(4)C	CDR35BP682B(3)W(4)
7,500	F,J,K	C1825N752(3)1G(4)C	CDR35BP752B(3)W(4)
8,200	F,J,K	C1825N822(3)1G(4)C	CDR35BP822B(3)W(4)
9,100	F,J,K	C1825N912(3)1G(4)C	CDR35BP912B(3)W(4)
10,000	F,J,K	C1825N103(3)1G(4)C	CDR35BP103B(3)W(4)
50 Volt — BP — C1825 SIZE (MILITARY CDR35)			
11,000	F,J,K	C1825N113(3)5G(4)C	CDR35BP113A(3)W(4)
12,000	F,J,K	C1825N123(3)5G(4)C	CDR35BP123A(3)W(4)
13,000	F,J,K	C1825N133(3)5G(4)C	CDR35BP133A(3)W(4)
15,000	F,J,K	C1825N153(3)5G(4)C	CDR35BP153A(3)W(4)
16,000	F,J,K	C1825N163(3)5G(4)C	CDR35BP163A(3)W(4)
18,000	F,J,K	C1825N183(3)5G(4)C	CDR35BP183A(3)W(4)
20,000	F,J,K	C1825N203(3)5G(4)C	CDR35BP203A(3)W(4)
22,000	F,J,K	C1825N223(3)5G(4)C	CDR35BP223A(3)W(4)
100 Volt — BX — C1825 SIZE (MILITARY CDR35)			
56,000	K,M	C1825N563(3)1X(4)C	CDR35BX563B(3)W(4)
68,000	K,M	C1825N683(3)1X(4)C	CDR35BX683B(3)W(4)
82,000	K,M	C1825N823(3)1X(4)C	CDR35BX823B(3)W(4)
100,000	K,M	C1825N104(3)1X(4)C	CDR35BX104B(3)W(4)
120,000	K,M	C1825N124(3)1X(4)C	CDR35BX124B(3)W(4)
150,000	K,M	C1825N154(3)1X(4)C	CDR35BX154B(3)W(4)
50 Volt — BX — C1825 SIZE (MILITARY CDR35)			
180,000	K,M	C1825N184(3)5X(4)C	CDR35BX184A(3)W(4)
220,000	K,M	C1825N224(3)5X(4)C	CDR35BX224A(3)W(4)
270,000	K,M	C1825N274(3)5X(4)C	CDR35BX274A(3)W(4)
330,000	K,M	C1825N334(3)5X(4)C	CDR35BX334A(3)W(4)
390,000	K,M	C1825N394(3)5X(4)C	CDR35BX394A(3)W(4)
470,000	K,M	C1825N474(3)5X(4)C	CDR35BX474A(3)W(4)

- (1) To complete Part Number for Dielectric, insert P or X symbol – as defined by Military specification.
- (2) To complete Part Number for Dielectric, insert G or X symbol. ("G" for Military "BP," or "X" for Military "BX.")
- (3) To complete Part Number, insert Capacitance Tolerance Symbol (when applicable) as available in MIL-PRF-55681: B – ±0.1 pF, C – ±0.25 pF, D – ±0.5pF, F – ±1%, J – ±5%, K – ±10%, M – ±20%. **NOTE: Available tolerances are listed in columns above.**
- (4) To complete Part Number, insert Failure Rate Symbol: M –1.0%; P –0.1%; R –0.01%; S –.001%.

Note: All MIL-PRF-55681 and KEMET Part Numbers tabulated above assume use of Solderguard II (MIL-PRF-55681 "W"; KEMET "C") end metal-ization. If MIL-PRF-55681 "U" or "S" (KEMET "H") or MIL-PRF-55681 "Y" (KEMET "C") is required, please change designators accordingly.

MIL-PRF-55681 MAXIMUM INDIVIDUAL PACKAGING QUANTITIES

CHIP SIZE	BULK - ANTI-STATIC			CHIP SIZE	BULK - ANTI-STATIC		
	REELED	STD BAG	BAG		REELED	STD BAG	BAG
C0805	2,500	25,000	10,000	C1808	2,500	7,500	3,000
C1206	2,500	25,000	10,000	C1812	1,100	7,500	3,000
C1210	2,500	25,000	10,000	C1825	1,100	7,500	1,000
C1805	2,500	7,500	3,000	C2225	1,100	5,000	1,000

MIL-PRF-55681 chips available in 7" reels only.

Tape & Reel Packaging

KEMET offers Multilayer Ceramic Chip Capacitors packaged in 8mm and 12mm plastic tape on 7" and 13" reels in accordance with EIA standard 481-1: Taping of surface mount components for automatic handling. This packaging system is compatible with all tape fed automatic pick and place systems. See page 52 for details on reeling quantities for commercial chips and page 59 for MIL-PRF-55681 chips.

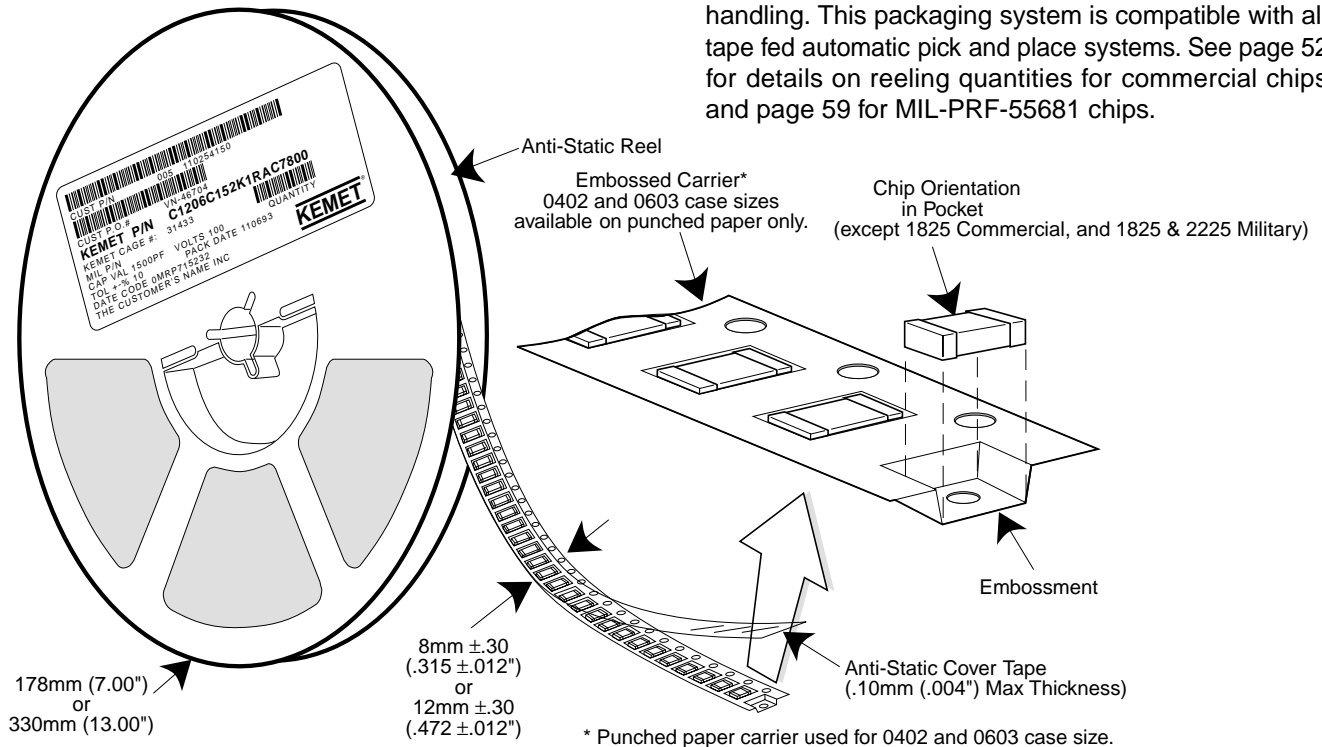

Performance Notes

- Cover Tape Break Force:** 1.0 Kg Minimum.
- Cover Tape Peel Strength:** The total peel strength of the cover tape from the carrier tape shall be:

Tape Width	Peel Strength
8 mm	0.1 Newton to 1.0 Newton (10g to 100g)
12 mm	0.1 Newton to 1.3 Newton (10g to 130g)

The direction of the pull shall be opposite the direction of the carrier tape travel. The pull angle of the carrier tape shall be 165° to 180° from the plane of the carrier tape. During peeling, the carrier and/or cover tape shall be pulled at a velocity of 300 ±10 mm/minute.
- Reel Sizes:** Molded tantalum capacitors are available on either 180 mm (7") reels (standard) or 330 mm (13") reels (with C-7280). Note that 13" reels are preferred.
- Labeling:** Bar code labeling (standard or custom) shall be on the side of the reel opposite the sprocket holes. Refer to EIA-556.

Embossed Carrier Tape Configuration: Figure 1

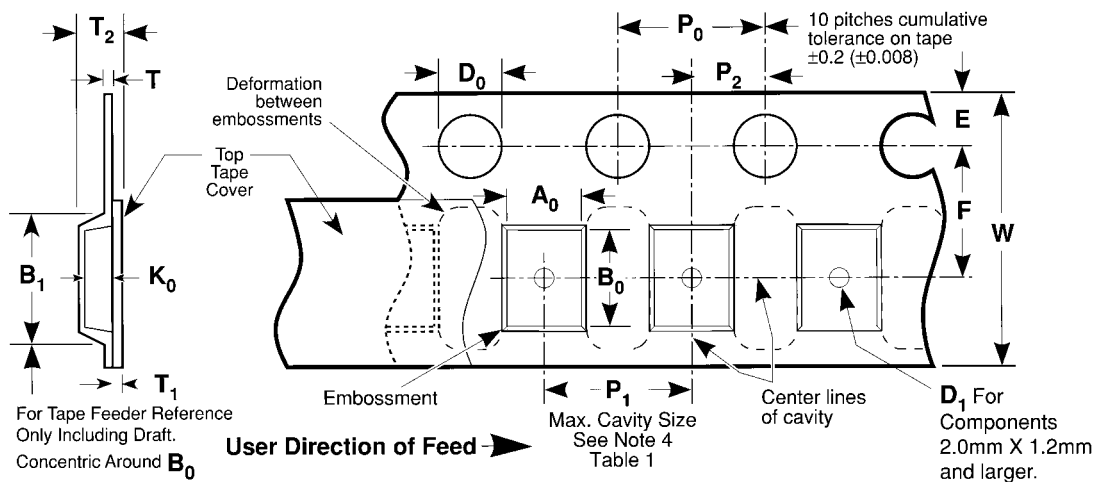

Table 1 — EMBOSSED TAPE DIMENSIONS (Metric will govern)

Constant Dimensions — Millimeters (Inches)									
Tape Size	D ₀	E	P ₀	P ₂	T Max	T ₁ Max			
8 mm and 12 mm	1.5 +0.10 -0.0 (0.059 +0.004, -0.0)	1.75 ±0.10 (0.069 ±0.004)	4.0 ±0.10 (0.157 ±0.004)	2.0 ±0.05 (0.079 ±0.002)	0.600 (0.024)	0.100 (0.004)			
Variable Dimensions — Millimeters (Inches)									
Tape Size	Pitch	B, Max. Note 1	D ₁ Min. Note 2	F	P ₁	R Min. Note 3	T ₂ Max	W	A ₀ B ₀ K ₀ Note 4
8 mm	Single (4 mm)	4.4 (0.173)	1.0 (0.039)	3.5 ±0.05 (0.138 ±0.002)	4.0 ±0.10 (0.157 ±0.004)	25.0 (0.984)	2.5 (0.098)	8.0 +0.3 -0.1 (0.315 +0.012, -0.004)	
12 mm	Double (8 mm)	8.2 (0.323)	1.5 (0.059)	5.5 ±0.05 (0.217 ±0.002)	8.0 ±0.10 (0.315 ±0.004)	30.0 (1.181)	4.6 (0.181)	12.0 ±0.30 (0.472 ±0.012)	

NOTES

- B1 dimension is a reference dimension for tape feeder clearance only.
- The embossment hole location shall be measured from the sprocket hole controlling the location of the embossment. Dimensions of embossment location and hole location shall be applied independent of each other.
- Tape with components shall pass around radius "R" without damage (see sketch A). The minimum trailer length (Fig. 2) may require additional length to provide R min. for 12 mm embossed tape for reels with hub diameters approaching N min. (Table 2)
- The cavity defined by A₀, B₀, and K₀ shall be configured to surround the part with sufficient clearance such that the chip does not protrude beyond the sealing plane of the cover tape, the chip can be removed from the cavity in a vertical direction without mechanical restriction, rotation of the chip is limited to 20 degrees maximum in all 3 planes, and lateral movement of the chip is restricted to 0.5 mm maximum in the pocket (not applicable to vertical clearance.)

Tantalum & Embossed Carrier Tape Configuration (cont.)

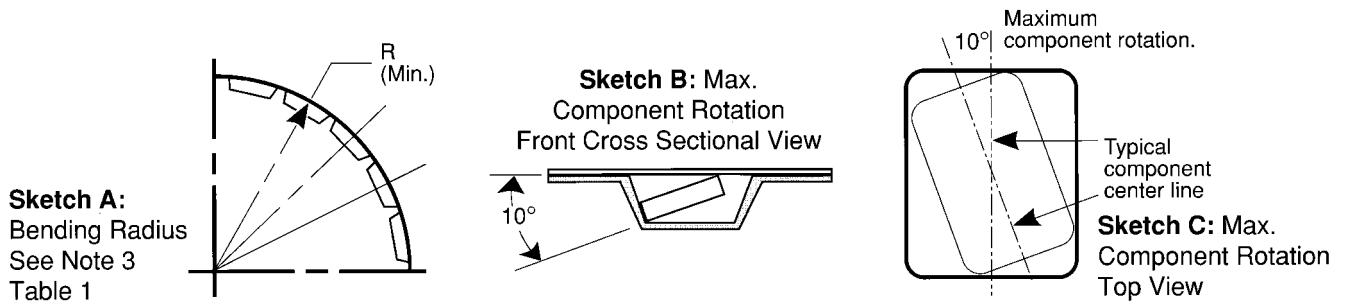

Sketch D: Tape Camber (Top View)

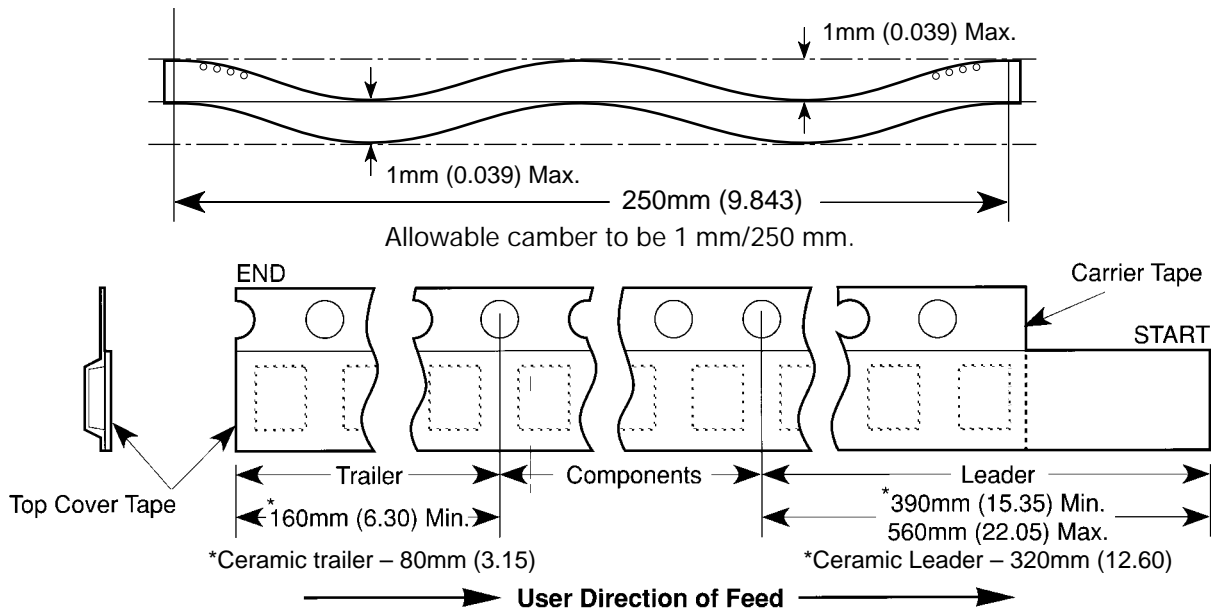

Figure 2: Tape Leader & Trailer Dimensions (Metric Dimensions Will Govern)

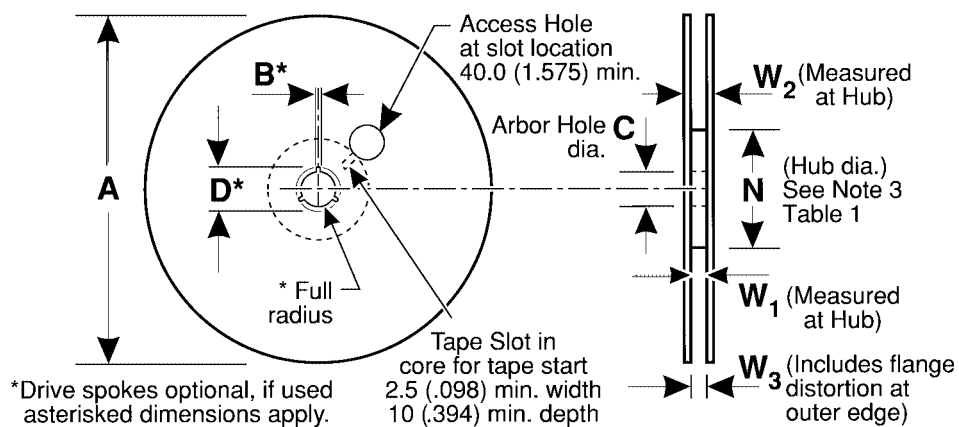

Figure 3: Reel Dimensions (Metric Dimensions will govern)

Table 2 – REEL DIMENSIONS (Metric will govern)

Tape Size	A Max	B^* Min	C	D^* Min	N Min	W_1	W_2 Max	W_3
8 mm	330.0 (12.992)	1.5 (0.059)	13.0 ± 0.20 (0.512 ± 0.008)	20.2 (0.795)	50.0 (1.969) See Note 3	8.4 +1.5, -0.0 (0.331 +0.059, -0.0)	14.4 (0.567)	7.9 Min (0.311) 10.9 Max (0.429)
12 mm	330.0 (12.992)	1.5 (0.059)	13.0 ± 0.20 (0.512 ± 0.008)	20.2 (0.795)	Table 1	12.4 +2.0, -0.0 (0.488 +0.078, -0.0)	18.4 (0.724)	11.9 Min (0.469) 15.4 Max (0.606)

Punched Carrier (Paper Tape) Configuration (Ceramic Chips Only):

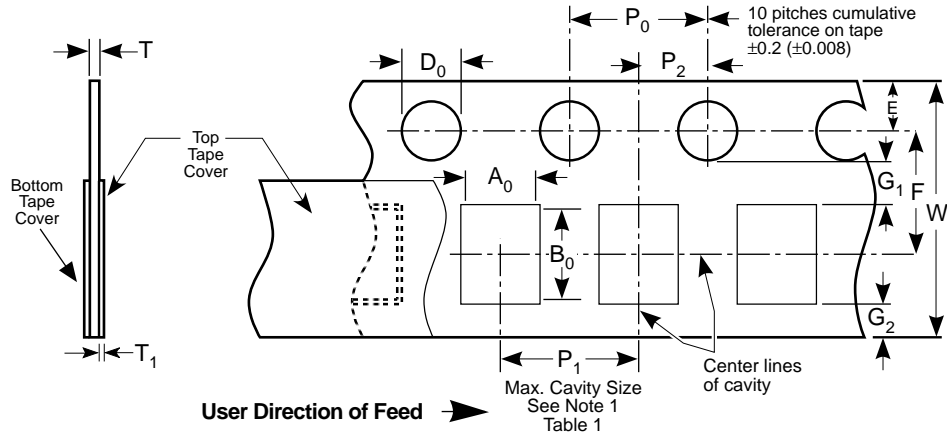

Table 1: 8 & 12mm Punched Tape
(Metric Dimensions Will Govern)

Constant Dimensions - Millimeters (Inches)

Tape Size	D ₀	E	P ₀	P ₂	T ₁	G ₁	G ₂	R Min.
8mm and 12mm	1.5 +0.10, -0.0 (.059 +0.004, -0.0)	1.75 ±0.10 (.069 ±0.004)	4.0 ± 0.10 (.157 ± 0.004)	2.0 ± 0.05 (.079 ± 0.002)	0.10 (.004) Max.	0.75 (.030) Min.	0.75 (.030) Min.	25 (.984) See Note 2 Table 1

Table 1: 8 & 12mm Punched Tape
(Metric Dimensions Will Govern)

Variable Dimensions - Millimeters (Inches)

Tape Size	P ₁	F	W	A ₀ B ₀	T
8mm 1/2 Pitch	2.0 ± 0.10 (.079 ±.004) See Requirements Section 3.3 (d)	3.5 ± 0.05 (.138 ± .002)	8.0 + 0.3, - 0.1 (.315 + .012, -.004)	See Note 1 Table 1	1.1mm (.043) Max. for Paper Base Tape and 1.6mm (.063) Max. for Non- Paper Base Compositions. See Note 3.
8mm	4.0 ± 0.10 (0.157 ± .004)				
12mm	4.0 ± 0.10 (0.157 ± .004)	5.5 ± 0.05 (.217 ± .002)	12.0 ± 0.3 (.472 ± .012)		
12mm Double Pitch	8.0 ± 0.10 (0.315 ± .004)				

Note:

- A₀, B₀ and T determined by the maximum dimensions to the ends of the terminals extending from the body and/or the body dimensions of the component. The clearance between the ends of the terminals or body of the component to the sides and depth of the cavity (A₀, B₀ and T) must be within 0.05mm (.002) minimum and 0.50mm (.020) maximum. The clearance allowed must also prevent rotation of the component within the cavity of not more than 20 degrees (see sketches A and B).
- Tape with components shall pass around radius "R" without damage.
- KEMET nominal thicknesses are: 0402 = 0.6mm and all others 0.95mm minimum.

Sketch A:
Bending Radius
See Note 2
Table 1

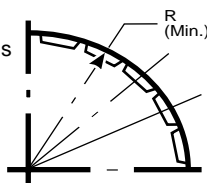

Sketch B:
Max. Component
Rotation - Front
Cross Sectional View

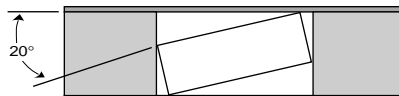

Sketch C:
Component Rotation - Top View

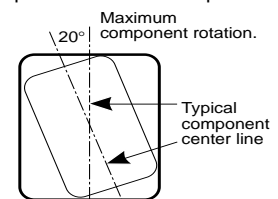

Bulk Cassette Packaging (Ceramic Chips only) (Meets Dimensional Requirements IEC-286-6 and EIAJ 7201)

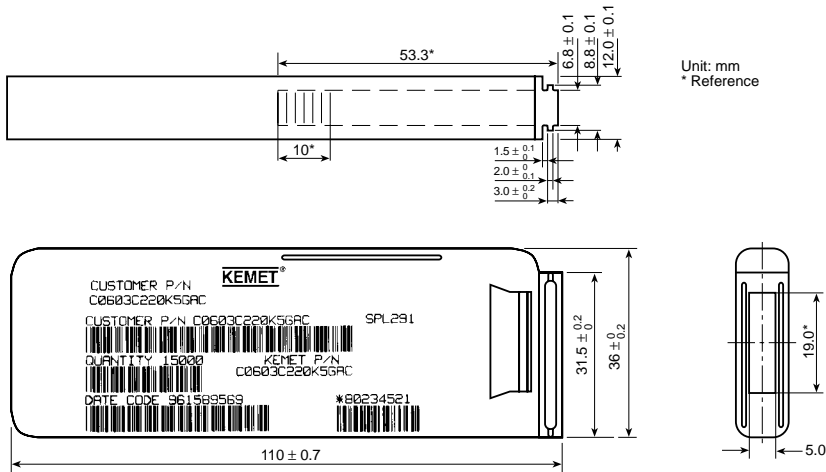

Table 2 – Capacitance Values Available In Bulk Cassette Packaging

Case Size	Dielectric	Voltage	Min. Cap Value	Max. Cap Value
0402	All	All	All	All
0603	All	All	All	All
0805	C0G	200	109	181
		100	109	331
		50	109	102
	X7R	200	221	392
		100	221	103
50		221	273	
25		221	104	
Y5V	25	104	224	
	16	104	224	

Table 1 – Capacitor Dimensions for Bulk Cassette Packaging – Millimeters

Metric Size Code	EIA Size Code	Length L	Width W	Thickness T	Bandwidth B	Minimum Separation S	Number of Pcs/Cassette
1005	0402	1.0 ± 0.05	0.5 ± 0.05	0.5 ± .05	0.2 to 0.4	0.3	50,000
1608	0603	1.6 ± 0.07	0.8 ± 0.07	0.8 ± .07	0.2 to 0.5	0.7	15,000
2012	0805	2.0 ± 0.10	1.25 ± 0.10	0.6 ± .10	0.5 to 0.75	0.75	10,000

Terminations: KEMET nickel barrier layer with a tin overplate.

CAPACITOR MARKING TABLE (Marking Optional - Not Available for 0402 Size or Y5V Dielectric)

Alpha Character	Capacitance (pF) For Various Numerical Identifiers									
	9	0	1	2	3	4	5	6	7	
A	0.10	1.0	10	100	1000	10,000	100,000	1,000,000	10,000,000	
B	0.11	1.1	11	110	1100	11,000	110,000	1,100,000	11,000,000	
C	0.12	1.2	12	120	1200	12,000	120,000	1,200,000	12,000,000	
D	0.13	1.3	13	130	1300	13,000	130,000	1,300,000	13,000,000	
E	0.15	1.5	15	150	1500	15,000	150,000	1,500,000	15,000,000	
F	0.16	1.6	16	160	1600	16,000	160,000	1,600,000	16,000,000	
G	0.18	1.8	18	180	1800	18,000	180,000	1,800,000	18,000,000	
H	0.20	2.0	20	200	2000	20,000	200,000	2,000,000	20,000,000	
J	0.22	2.2	22	220	2200	22,000	220,000	2,200,000	22,000,000	
K	0.24	2.4	24	240	2400	24,000	240,000	2,400,000	24,000,000	
L	0.27	2.7	27	270	2700	27,000	270,000	2,700,000	27,000,000	
M	0.30	3.0	30	300	3000	30,000	300,000	3,000,000	30,000,000	
N	0.33	3.3	33	330	3300	33,000	330,000	3,300,000	33,000,000	
P	0.36	3.6	36	360	3600	36,000	360,000	3,600,000	36,000,000	
Q	0.39	3.9	39	390	3900	39,000	390,000	3,900,000	39,000,000	
R	0.43	4.3	43	430	4300	43,000	430,000	4,300,000	43,000,000	
S	0.47	4.7	47	470	4700	47,000	470,000	4,700,000	47,000,000	
T	0.51	5.1	51	510	5100	51,000	510,000	5,100,000	51,000,000	
U	0.56	5.6	56	560	5600	56,000	560,000	5,600,000	56,000,000	
V	0.62	6.2	62	620	6200	62,000	620,000	6,200,000	62,000,000	
W	0.68	6.8	68	680	6800	68,000	680,000	6,800,000	68,000,000	
X	0.75	7.5	75	750	7500	75,000	750,000	7,500,000	75,000,000	
Y	0.82	8.2	82	820	8200	82,000	820,000	8,200,000	82,000,000	
Z	0.91	9.1	91	910	9100	91,000	910,000	9,100,000	91,000,000	
a	0.25	2.5	25	250	2500	25,000	250,000	2,500,000	25,000,000	
b	0.35	3.5	35	350	3500	35,000	350,000	3,500,000	35,000,000	
d	0.40	4.0	40	400	4000	40,000	400,000	4,000,000	40,000,000	
e	0.45	4.5	45	450	4500	45,000	450,000	4,500,000	45,000,000	
f	0.50	5.0	50	500	5000	50,000	500,000	5,000,000	50,000,000	
m	0.60	6.0	60	600	6000	60,000	600,000	6,000,000	60,000,000	
n	0.70	7.0	70	700	7000	70,000	700,000	7,000,000	70,000,000	
t	0.80	8.0	80	800	8000	80,000	800,000	8,000,000	80,000,000	
y	0.90	9.0	90	900	9000	90,000	900,000	9,000,000	90,000,000	

Laser marking is available as an extra-cost option for most KEMET ceramic chips. Such marking is two sided, and includes a \bar{K} to identify KEMET, followed by two characters (per EIA-198 - see table below) to identify the capacitance value. Note that marking is not available for size 0402 nor for any Y5V chip. In addition, the 0603 marking option is limited to the \bar{K} only.

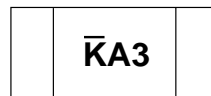

Example shown is 1,000 pF capacitor.