

NEW

1 mm-Pitch Low Profile Connector System for Wire to PCB Applications Suitable for use with Discrete Wire, FPC or Fine Coaxial Cable.

DF19 Series

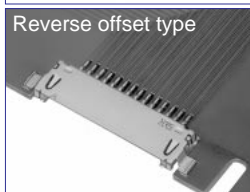
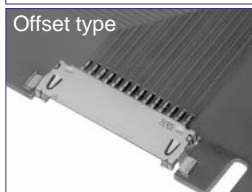
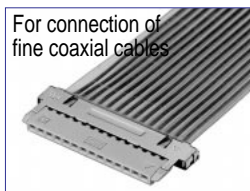
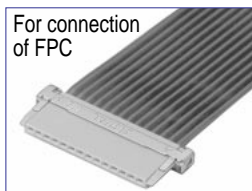
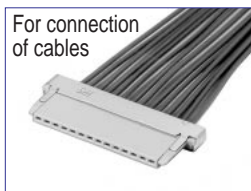
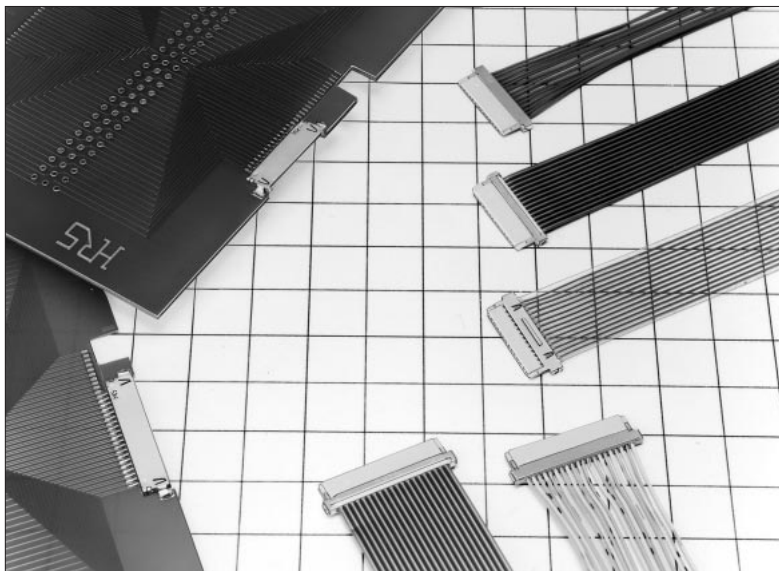

■ Features

1. Ultra Low Profile

FPC type: Max. 1.7 mm thick
Discrete Wire & Coaxial 1.5 mm thick

2. SMT HEADERS Suit all Sockets

Each header can connect to three different sockets (cable, FPC, and fine coaxial cable type).
(Note: Fine coaxial cable type is under development.)

3. Standardised Outer Dimensions

The three sockets have the same outside dimensions to allow complete Flexibility.

4. Many Variations

There are headers of the on-board, offset, and reverse offset types to accommodate all designs.

5. Connection to a Metal GROUND Plate

Ground lines can be connected to a metal shell for shielding.

■ Application

LCDs, notebook personal computers, small OA machines, and small consumer products

Drawing of mated connectors on a DF19G- *P-1H board

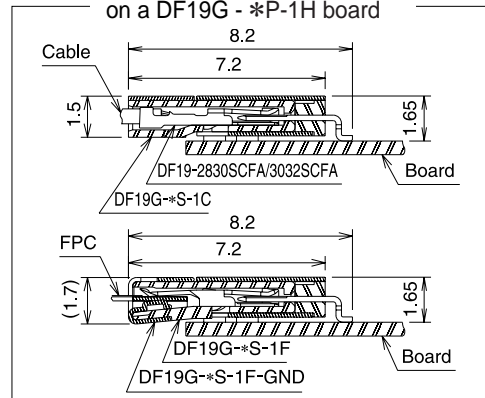

Drawing of mated connectors on a DF19K- *P-1H board

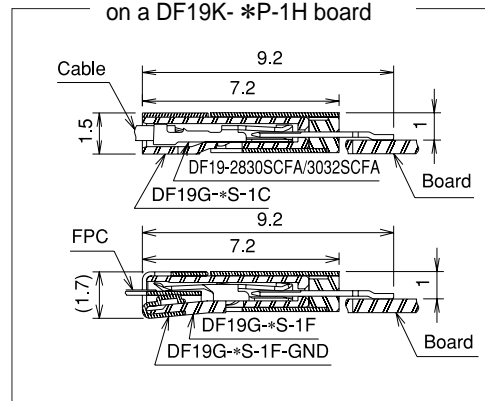

Drawing of mated connectors on a DF19L- *P-1H board

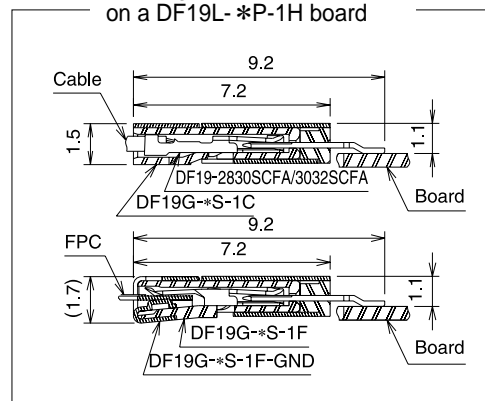

Drawing of mated connectors on a DF19KR- *P-1H board

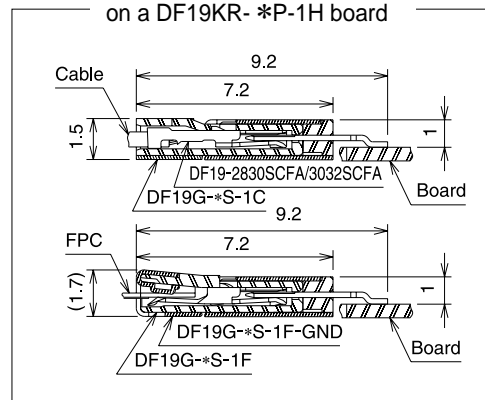

Product Specifications

Rating	Rated current	AWG#28 : 1A AWG#30 : 0.5A AWG#32 : 0.3A FPC : 0.5A Fine coaxial cable AWG# 40: 0.3A	Operating temperature range	-35~85°C Note 1 Note 2	Storage temperature range	-10~60°C Note 2
	Rated voltage	AC100V	Operating humidity range	20~80%	Storage humidity range	40~70%

Item	Specification	Conditions
1. Insulation resistance	500MW or more	Measure at DC100V.
2. Voltage proof	No flashover or breakdown	300 V AC, applied for one minute.
3. Contact resistance	30mW or less (50mW or less for FPC)	Measure at 100 mA.
4. Insertion-Extraction Force (per Contact)	MIN 0.2N(20gf), MAX 3N(300gf)	Measure with a steel pin with thickness of 0.2±0.005.
5. Vibration	No electrical discontinuity for 1μs or more	Frequency: 10 Hz to 55 Hz, amplitude of 0.75 mm in 3 directions, 2h
6. Damp heat	Contact resistance: specified value or less, insulation resistance: 500MW or more	Temperature of 40±2-C, humidity of 90% to 95%, duration 96h
7. Temperature Cycling	Contact resistance: specified value or less, insulation resistance: 500MW or more	(-55-C: 30 min -> 5-C to 35-C: 10 min -> 85-C: 30 min -> 5-C to 35-C: 10 min) 5 cycles
8. Mechanical operation	Contact resistance: specified value or less	50 mechanical-operation cycles
9. Resistance to soldering heat	No melting of resin portion, which affects performance	Reflow: At the recommended temperature profile, manual soldering: iron temperature 300-C for 3s

Note1: Includes the temperature rise due to current flow.

Note2: The term storage refers to unused products prior to PCB mounting that is being stored for long periods.

The operating temperature and humidity range are applicable to connectors not carrying current. After PCB assembly or temporary storage during transportation.

Note3: The aforementioned specifications are representative of this series. For information on specific parts, confirm with Sales Office.

Material

Product	Part	Material	Color / Finish	UL standard
Pin header	Insulation	Polyamide resin	Grey	UL94V-0
	Terminal	Phosphor bronze	Selective Gold Plating	—
	Ground Plate	Phosphor bronze	Tin Plated	—
Socket	Insulation	Polyamide resin	Grey	UL94V-0
	Ground Plate	Stainless steel	Tin Plated	—
Crimp-Contact	Terminal	Phosphor bronze	Gold Plated	—
FPC socket	Insulation	Polyamide resin	Grey	UL94V-0
	Terminal	Phosphor bronze	Selective Gold Plating	—
Ground plate for FPC	Ground Plate	Stainless steel	Tin Plated	—
Socket for fine coaxial cables	Insulation	LCP resin	Grey	UL94V-0
	Terminal	Phosphor bronze	Selective Gold Plating	—
	Ground Plate	Phosphor bronze	Tin Plated	—
Ground plate for fine coaxial cables	Ground Plate	Phosphor bronze	Tin Plated	—

Note1: Tinning is Whisker free

Part Number Construction

The type name DF19 represents a specific product specification.

To order a product, specify the type from pages 4 to 9.

Connector

DF 19 # - * P - 1 H
① ② ③ ④ ⑤ ⑥ ⑦

DF 19 # - * S - 1 F - GND
① ② ③ ④ ⑤ ⑥ ⑦ ⑧

① Series Name : DF ② Series No. : 19 ③ Profile : <ul style="list-style-type: none"> ■ Pin header <ul style="list-style-type: none"> G : On-board type (1.65 mm from the board) K : Offset type (1.0 mm from the board) L : Offset type (1.1 mm from the board) KR : Reverse offset type of DF19K (1.0 mm from the board) ■ Crimp socket <ul style="list-style-type: none"> None : Without grounding shell G : With grounding shell (protected for EMI) ■ FPC socket <ul style="list-style-type: none"> G : Specification for connection with ground shell ■ Ground plate for FPC <ul style="list-style-type: none"> G : Specification for connection with ground shell ■ Socket for coaxial fine cables <ul style="list-style-type: none"> G : Specification for connection with ground shell ■ Ground plate for fine coaxial cables <ul style="list-style-type: none"> G : Specification for connection with ground shell 	④ Number of contacts : 8,14,20,30... (Note 1) ⑤ Connector type S : Single row socket P : Single row pin header ⑥ Contact pitch : 1mm ⑦ Wiring type / terminal profile H : Right angle SMT C : Crimp socket F : FPC socket SD : Socket for fine coaxial cables ⑧ Part for installation GND : Ground plate (Note 2)
--	---

(Note 1) Be careful, as the number of contacts differ depending on the profile.

(Note 2) The FPC and coaxial fine cable types always use a ground plate.

Terminal

DF19 - 2830 SCF A ()**
① ② ③ ④

① Symbol 2830 : AWG#28~30 3032 : AWG#30~32	③ Plating A : Gold plating
② Type SCF : Socket contact reel Packaging	④ Specification None : 10 000 pieces per reel 41 : 20 000 pieces per reel

Right Angle Pin Header (SMT) (On-board Type)

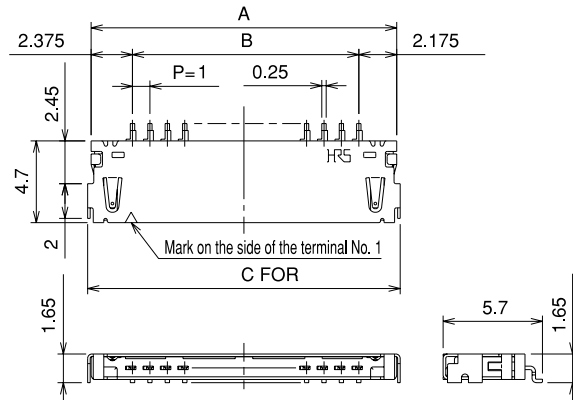
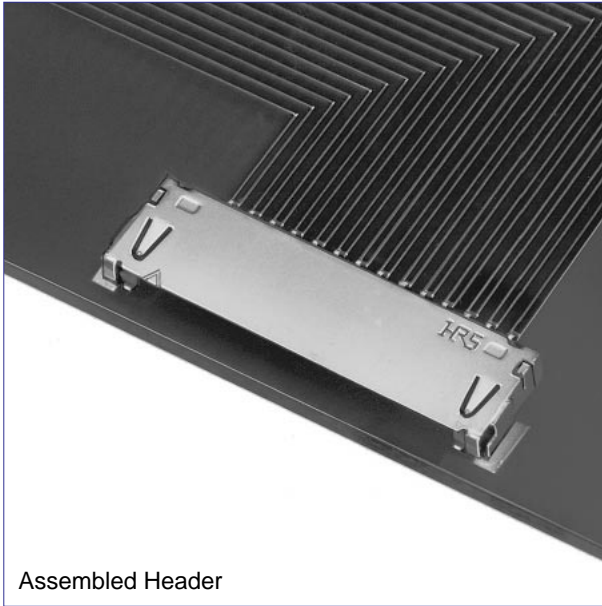

Recommended PCB Layout

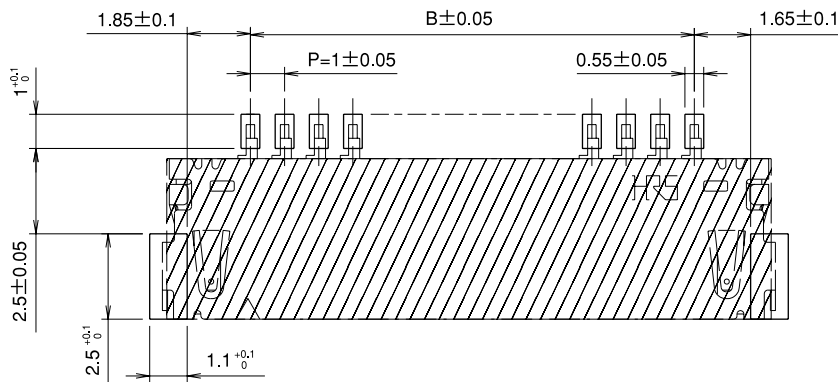

Note1: Masked area (hatched). Pattern in this area must be protected by resist.

Specification No.**, (**)
(59): Gold plating, Tape and reel packaging

Unit: mm

Product No.	HRS No.	Number of poles	A	B	C	Width of emboss	Remarks
DF19G- 8P-1H (**)	CL685-0021-0-*	8	11.55	7	11.95	24	1.65 mm from the board
DF19G-14P-1H (**)	CL685-0004-0-*	14	17.55	13	17.95	44	
DF19G-20P-1H (**)	CL685-0006-6-*	20	23.55	19	23.95	44	
DF19G-30P-1H (**)	CL685-0015-7-*	30	33.55	29	33.95	44	

Note1: Specify the number of reels to order tape and reel packaging (1 000 pieces per reel).

Right Angle Pin Header (SMT) (Offset Type)

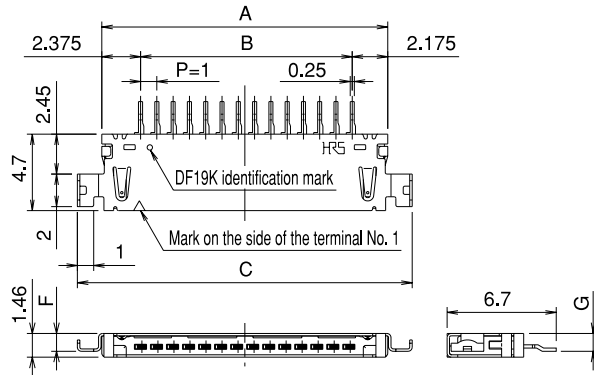
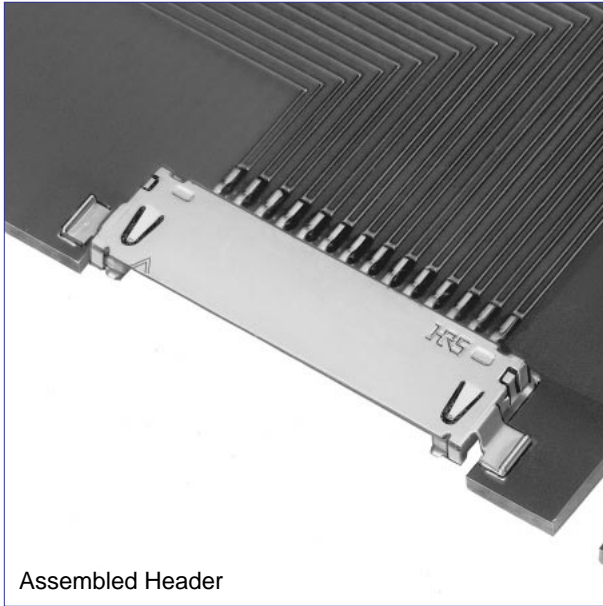

Recommended PCB Layout

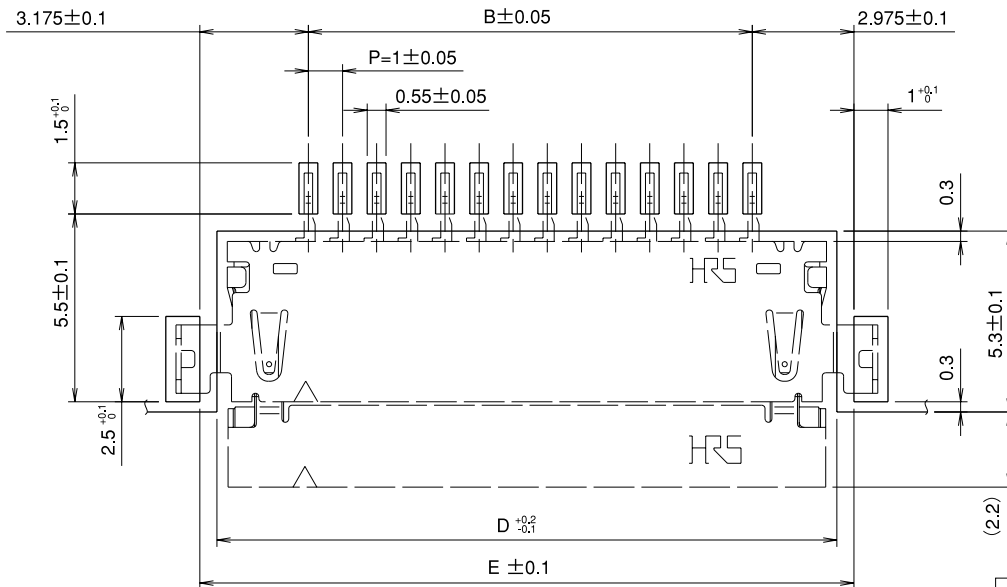

Specification No.** *(**)
(59): Gold plating

Unit: mm

Product No.	HRS No.	Number of poles	A	B	C	D	E	Width of emboss	Remarks
DF19K-20P-1H (**)	CL685-0008-1-**	20	23.55	19	26.55	24.15	25.15	44	1.0 mm from the board
DF19K-30P-1H (**)	CL685-0032-6-**	30	33.55	29	36.55	34.15	35.15	56	

Product No.	HRS No.	Number of poles	A	B	C	D	E	Width of emboss	Remarks
DF19L-14P-1H (**)	CL685-0003-8-**	14	17.55	13	20.55	18.15	19.15	44	1.1 mm from the board
DF19L-20P-1H (**)	CL685-0019-8-**	20	23.55	19	26.55	24.15	25.15	44	
DF19L-30P-1H (**)	CL685-0016-0-**	30	33.55	29	36.55	34.15	35.15	56	

Note1: Specify the number of reels to order tape and reel packaging (1 000 pieces per reel).

Right Angle Pin Header (SMT) (Reverse Offset Type)

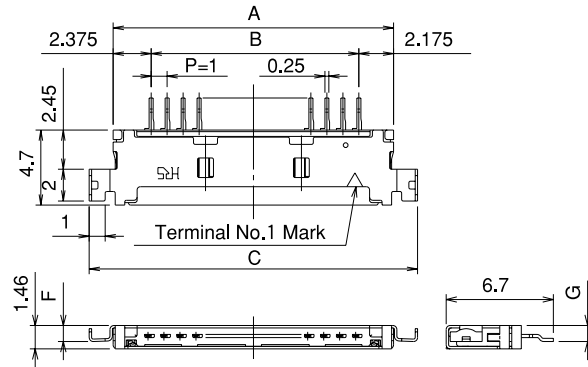
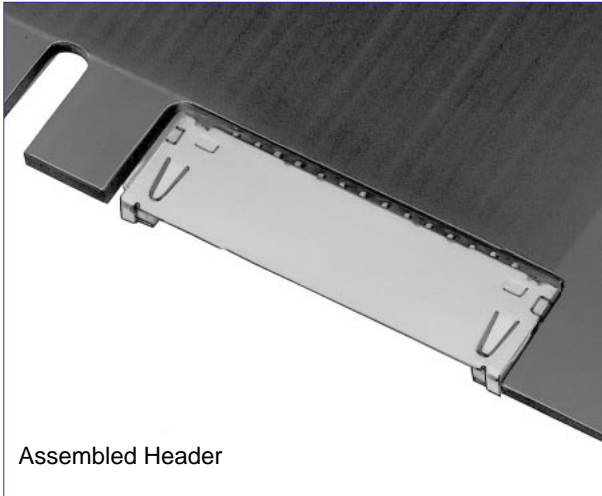

Recommended PCB Layout

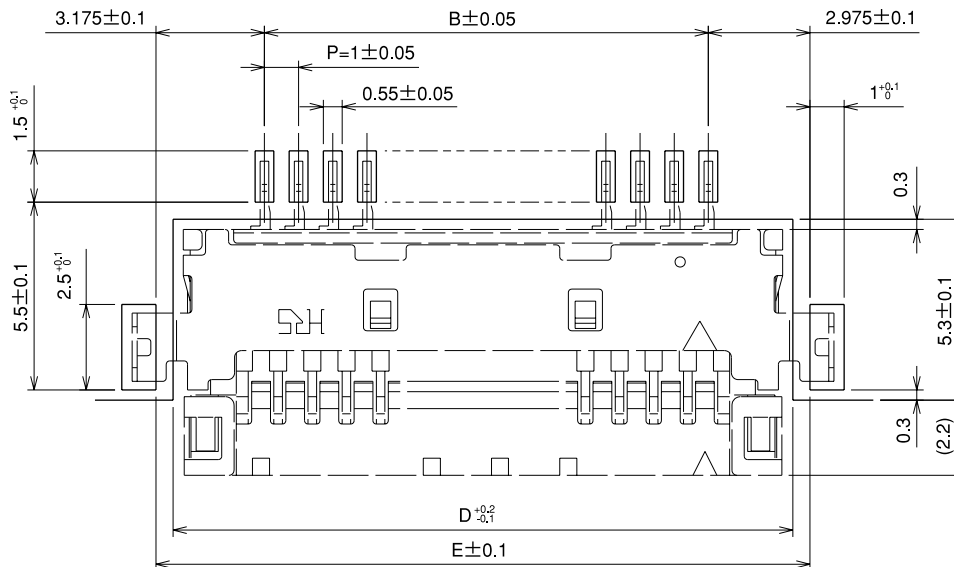

Specification No.** (* *)
(59): Gold plating

Unit: mm

Product No.	HRS No.	Number of poles	A	B	C	D	E	Width of emboss	Remarks
DF19KR-14P-1H (* *)	CL685-0024-8-* *)	14	17.55	13	20.55	18.15	19.15	44	1.0 mm from the board
DF19KR-20P-1H (* *)	CL685-0023-5-* *)	20	23.55	19	26.55	24.15	25.15	44	

Note1: Specify the number of reels to order tape and reel packaging (1 000 pieces per reel).

Single Row Socket (Discrete Wire)

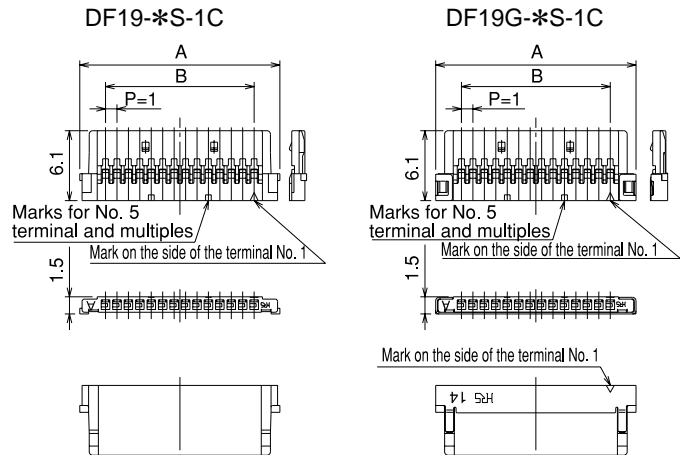

Specification No. **, (**)
None: 1 pack (100 pieces)

					Unit: mm				
Product No.	HRS No.	Number of poles	A	B	Product No.	HRS No.	Number of poles	A	B
DF19 - 8S-1C (**)	CL685-0029-1**	8	11.5	7	DF19G - 8S-1C (**)	CL685-0022-2**	8	11.5	7
DF19 - 14S-1C (**)	CL685-0012-9**	14	17.5	13	DF19G - 14S-1C (**)	CL685-0005-3**	14	17.5	13
DF19 - 20S-1C (**)	CL685-0011-6**	20	23.5	19	DF19G - 20S-1C (**)	CL685-0007-9**	20	23.5	19
DF19 - 30S-1C (**)	CL685-0013-1**	30	33.5	29	DF19G - 30S-1C (**)	CL685-0014-4**	30	33.5	29

Note1: Products are sold in bulk packs. To order, specify the number of packs (100 pieces per pack).

Socket Crimp Contact

Product No.	HRS No.	Type	Quantity	Color / Finish
DF19-2830SCF (**)	685-0001-2-	Reel terminal	10,000 pieces per reel	Gold plating
DF19-3032SCF (**)	685-0002-5-41	Reel terminal	20,000 pieces per reel	Gold plating

Specification No. **, (**)
None: 1 Reel 10,000 pieces per reel
(41) : 1 Reel 20,000 pieces per reel

Applicable Wire (tinned soft conductor)

Applicable wire size (core wire composition)	Sheath diameter
AWG#28 (7 strands/0.127 mm)	φ0.5 ~ φ0.6mm
AWG#30 (7 strands/0.1 mm)	
AWG#32 (7 strands/0.08 mm)	

Recommended Wire UL1571

Strip Length 1.2~1.9mm

Note1: Please contact us when you use wires other than those specified in the table.

Recommended Crimp Tooling

Type	Product No.	HRS No.
Applicator	AP105-DF19S	CL901-4571-3
Press	CM-105	CL901-0005-4
Manual crimping tool	HT302/DF19S	CL550-0284-7

Note1: Product is not guaranteed when non-specified tools are used.

Note2: Terminals are cut for manual crimping tool use.

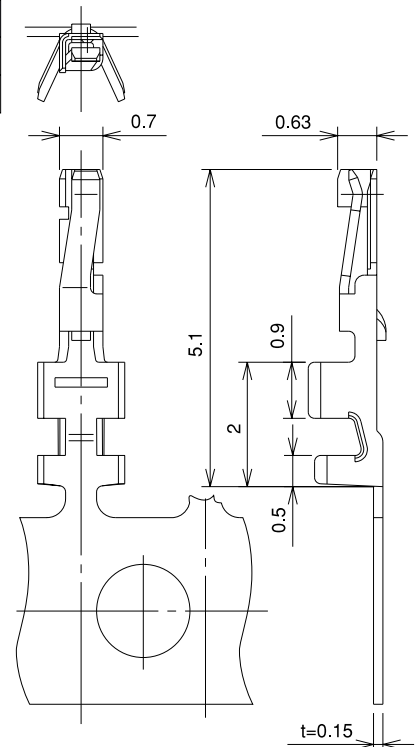

Single Row Socket (For FPC Cable)

Note1: Wiring of FPC requires a socket and a ground plate.



Assembled Socket

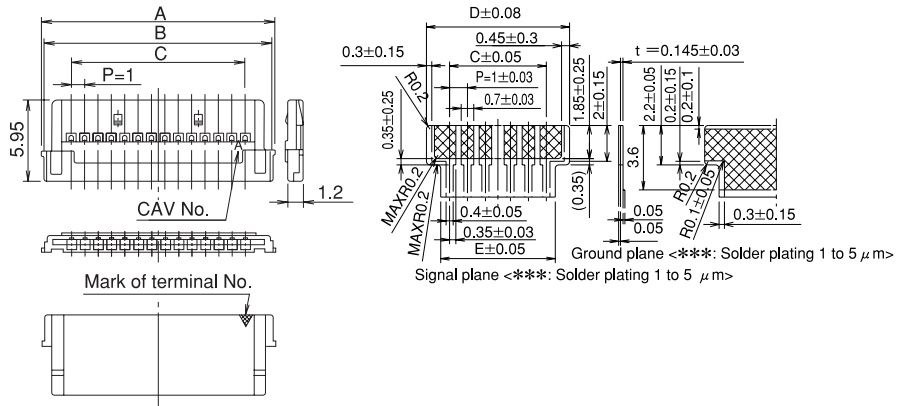

Unit: mm

Product No.	HRS No.	Number of Contacts	A	B	C	D	E
DF19G-14S-1F (**)	CL685-0017-2-**	14	17.5	17.1	13	15.6	14
DF19G-20S-1F (**)	CL685-0009-4-**	20	23.5	23.1	19	21.6	20
DF19G-30S-1F (**)	CL685-0033-9-**	30	33.5	33.1	29	31.6	30

Specification No. **, (***)
None: 1 pack (100 pieces)

Note1: Products are sold in bulk packs. To order, specify the number of packs (100 pieces per pack).

Ground Plate for FPC

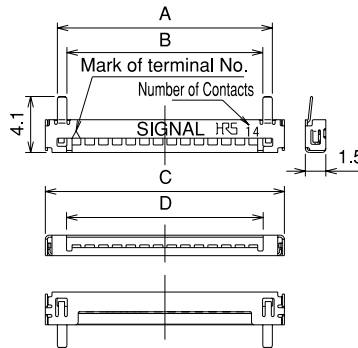

Unit: mm

Product No.	HRS No.	Number of Contacts	A	B	C
DF19G-14S-1F-GND (**)	CL685-0018-5-**	14	14.4	14.35	15.75
DF19G-20S-1F-GND (**)	CL685-0010-3-**	20	20.4	20.35	21.75
DF19G-30S-1F-GND (**)	CL685-0034-1-**	30	30.4	30.35	31.75

Specification No. **, (***)
None: 1 pack (100 pieces)

Note1: Products are sold in bulk packs. To order, specify the number of packs (100 pieces per pack).



Note1: See page 12 for the assembling method.

Applicable Assembling Tools

Type	Product No.	HRS No.
Desk-top tool (for 14 core wires)	DF19G-14S/PR-MD2	CL902-4514-6
Desk-top tool (for 20 core wires)	DF19G-20S/PR-MD2	CL902-4513-3
Desk-top tool (for 30 core wires)	DF19G-30S/PR-MD2	CL902-4518-7

Note1: Product is not guaranteed unless Hirose approved tools are used.



■Single Row Socket (Fine Coaxial Cable) ... (Under development)



Specification No. **, (**)
None: 1 pack (100 pieces)

Product No.	HRS No.	Number of poles
DF19G-14S-1SD (**)	—	14
DF19G-20S-1SD (**)	—	20

Note1: The products will be sold in bulk packs (100 pieces per pack). To order, specify the number of packs.

●Applicable Wire (Fine Coaxial Cable) ... Planned

Applicable wire size (core wire composition)	Sheath diameter
AWG#40(7strands/0.03mm)	$\phi 0.3 \sim \phi 0.4\text{mm}$

◆ Drawing of Tape and Reel Dimensions (as per JIS-C-0806)

●DF19G-**P-1H*

●DF19K-**P-1H*

●DF19L-**P-1H*

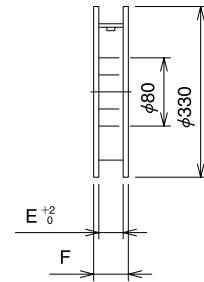
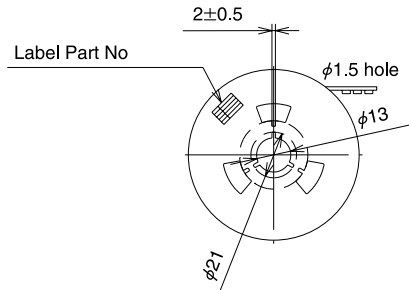
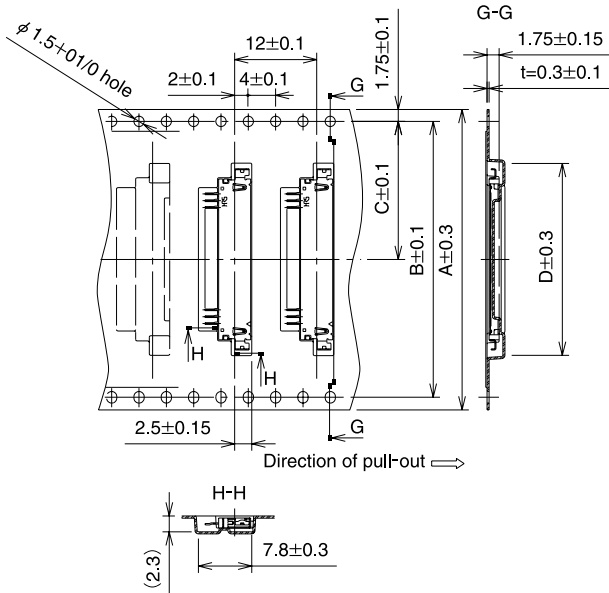

●DF19KR-**P-1H*

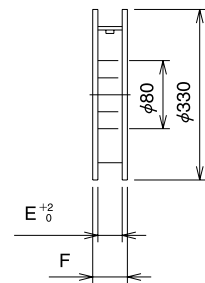
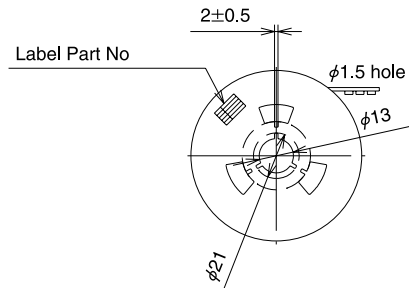
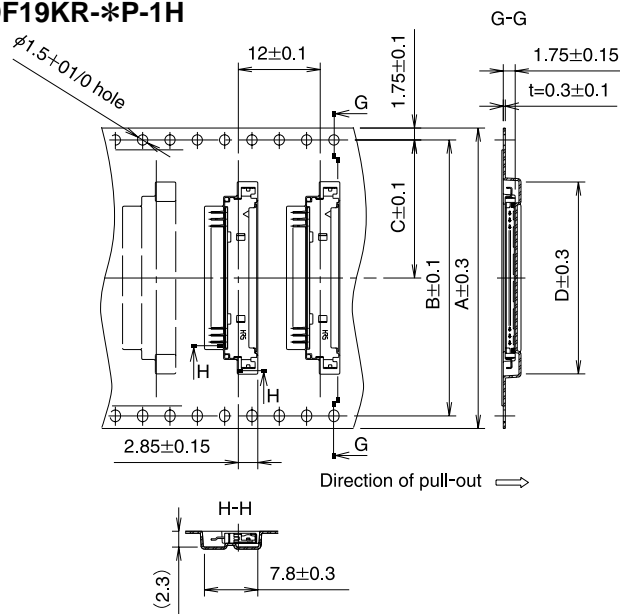

Unit: mm

Insertion connector	Number of Contacts	A	B	C	D	E	F	Remarks
DF19G - 8P-1H	8	24	—	11.5	16.1	24.4	30.4	On-board type (1.65 mm from the board)
DF19G -14P-1H	14	44	40.4	20.2	22.1	44.4	50.4	
DF19G -20P-1H	20	44	40.4	20.2	28.1	44.4	50.4	
DF19G -30P-1H	30	56	50.2	26.2	38.1	56.4	62.4	
DF19K -20P-1H	20	44	40.4	20.2	28.1	44.4	50.4	Offset type (1.0 mm from the board)
DF19K -30P-1H	30	56	52.4	26.2	38.1	56.4	62.4	
DF19L -14P-1H	14	44	40.4	20.2	22.1	44.4	50.4	Offset type (1.0 mm from the board)
DF19L -20P-1H	20	44	40.4	20.2	28.1	44.4	50.4	
DF19L -30P-1H	30	56	52.4	26.2	38.1	56.4	62.4	
DF19KR-14P-1H	14	44	40.4	20.2	22.1	44.4	50.4	Reverse offset type of DF19K (1.0 mm from the board)
DF19KR-20P-1H	20	44	40.4	20.2	28.1	44.4	50.4	

◆ Soldering Temperature Profile

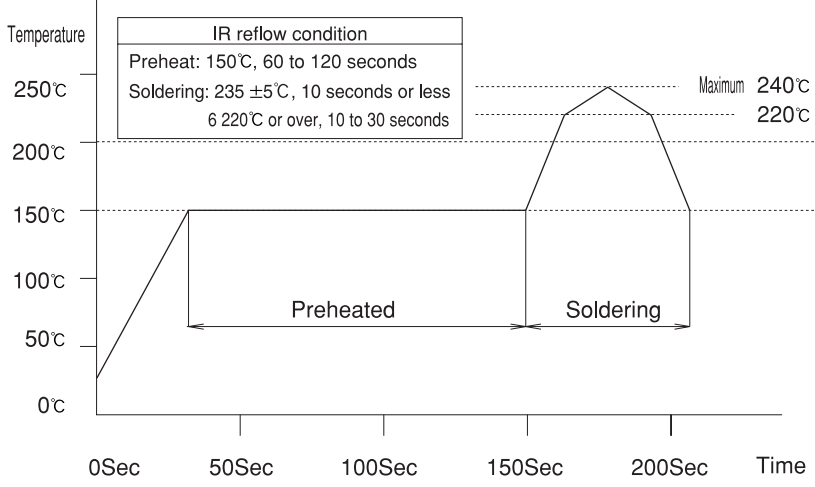
<p>1. Recommended temperature profile</p>	 <p>(Note 1) The temperature profile can be applied twice with the normal temperature profile. (Note 2) The temperature is measured at the connector lead.</p>
<p>2. Recommended manual soldering conditions</p>	<p>Soldering iron temperature $290 \pm 10^{\circ}\text{C}$, soldering time 3 seconds or less</p>
<p>3. Recommended screen thickness</p>	<p>0.15mm</p>
<p>4. Warpage of board</p>	<p>Max. 0.03mm at the connector center with the connector ends as the reference.</p>
<p>5. Cleaning</p>	<p>See the separate "Guide to Hirose Nylon connectors."</p>
<p>6. Wiring</p>	<p>See the separate "Guide to Hirose Nylon connectors." ■ As crimp terminals are extremely small, crimping must be performed with care: observe the directions in the "Crimping Condition Sheet" and "Crimping Standard Sheet."</p>
<p>7. Precautions</p>	<p>■ Due to the ultra miniature design care needs to be taken when disconnecting to avoid accidental damage.</p>

◆ Assembly Procedure for FPC Socket

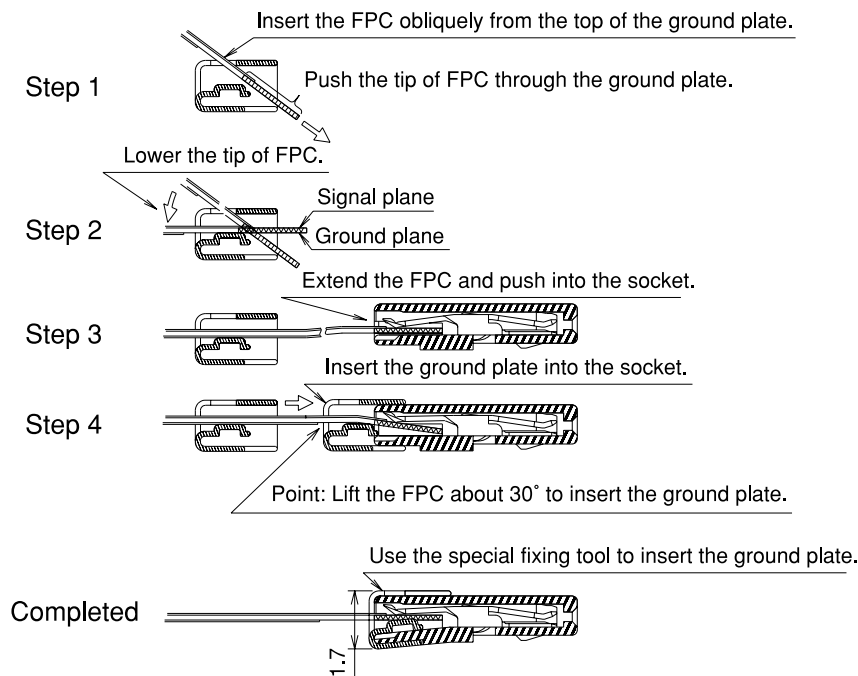

Note1: The ground plate and the socket are sold separately.

Note2: Use the special tool for assembling.

Note3: To insert the ground plate, lift the FPC about 30° to make a space for insertion. Don't apply excessive force (bending or gouging, as the FPC copper foil (end of the cover film) will crack.

Note4: If the ground plate doesn't enter the socket, don't apply excessive force, but check whether it is parallel with the socket.

Note5: To protect the FPC, insert or pull out the connector in parallel with the engagement plane.

Note6: To protect the FPC, don't apply excessive tension.

Note7: To bend the FPC, observe the allowable R and other conditions recommended by the manufacturer, and keep a distance between the bending point and the socket as shown in the illustration below.

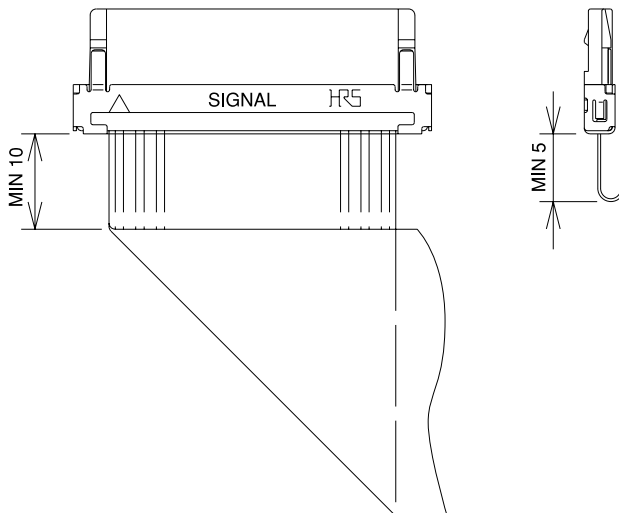

Note8: To assemble the FPC to the socket, use the recommended jigs and tools and be careful not to be injured by the edge of the metallic part of the connector. Observe the instructions given in the manual for wiring jigs and tools.

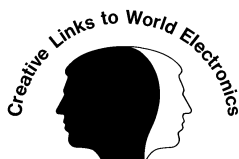

HIROSE ELECTRIC CO.,LTD.

5-23, OSAKI 5-CHOME, SHINAGAWA-WARD, TOKYO 141-8587, JAPAN

PHONE: 81-3-3491-9741

FAX :81-3-3493-2933