

REV	DESCRIPTION	DATE

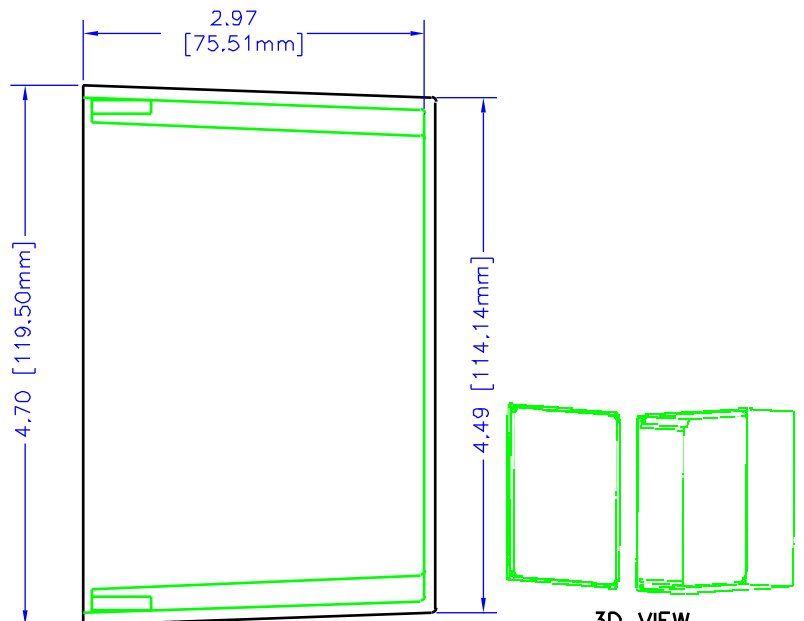
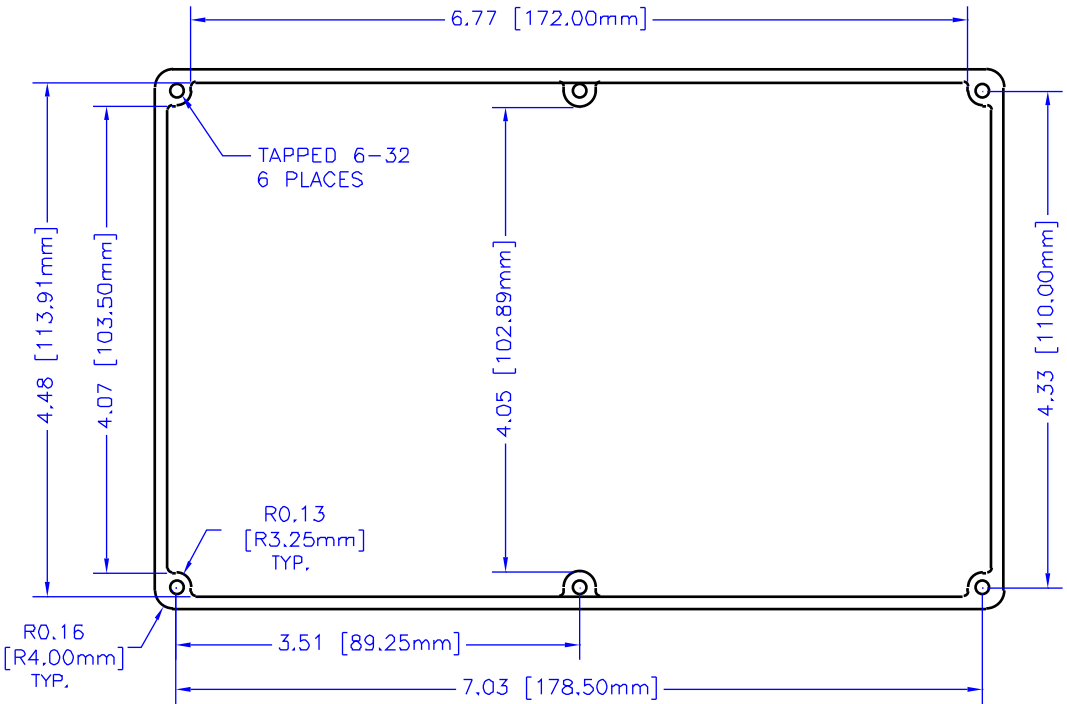
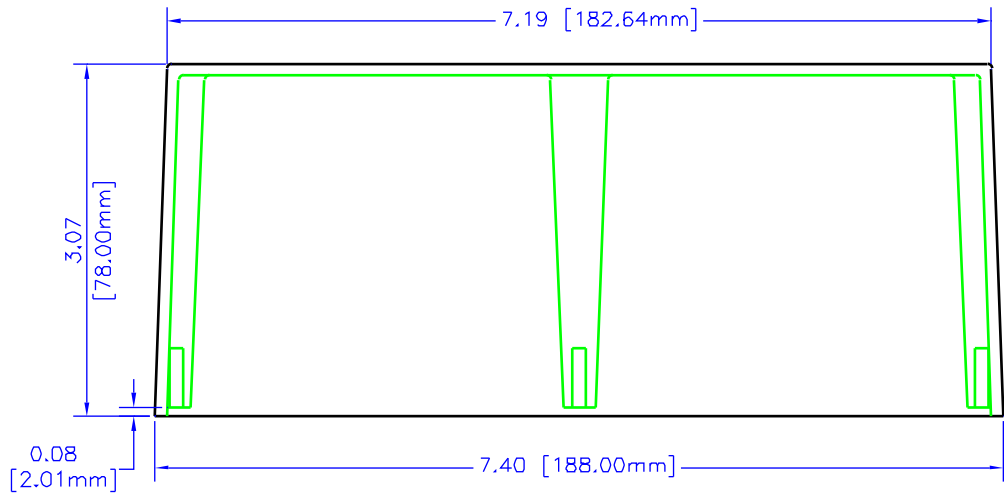

3D VIEW
(NOT TO SCALE)

NOTES

MATERIAL DIE-CAST ALUMINUM ALLOY 413(13)
PARTS ENCLOSURE BASE, LID AND EITHER 4, 6, OR 8 6-32X0.5" NICKEL PLATED MACHINE SCREWS, PAINTED BOXES COME WITH COLORED SCREWS, REPLACEMENT SCREWS ARE AVAILABLE, SEE CATALOG FOR DETAILS.
OPTIONS WATER RESISTANT SILICONE SEAL BY ADDING THE LETTER "W" AFTER 1590 IN THE PART NUMBER. SILICONE TEMP. RANGE IS -62C TO 232C (-80F TO 450F)
FINISH UNFINISHED (NO SUFFIX), BLACK POWDER ("BK" SUFFIX), GRAY POWDER ("GY" SUFFIX),

BOX

UNLESS OTHERWISE SPECIFIED
 DIMENSIONS ARE IN INCHES
 X +/- .1
 XX +/- .02
 XXX +/- .015
 CLTS +/- .005
 ANGLES +/- 5 DEG



WEB: WWW.HAMMONDMFG.COM

TITLE		HAMMOND 1590 SERIES DIE-CASTED ENCLOSURE	
DRAWN BY	MJM	DATE	08/30/01
SCALE		PAGE	1 OF 2
PART NUMBER	1590E		

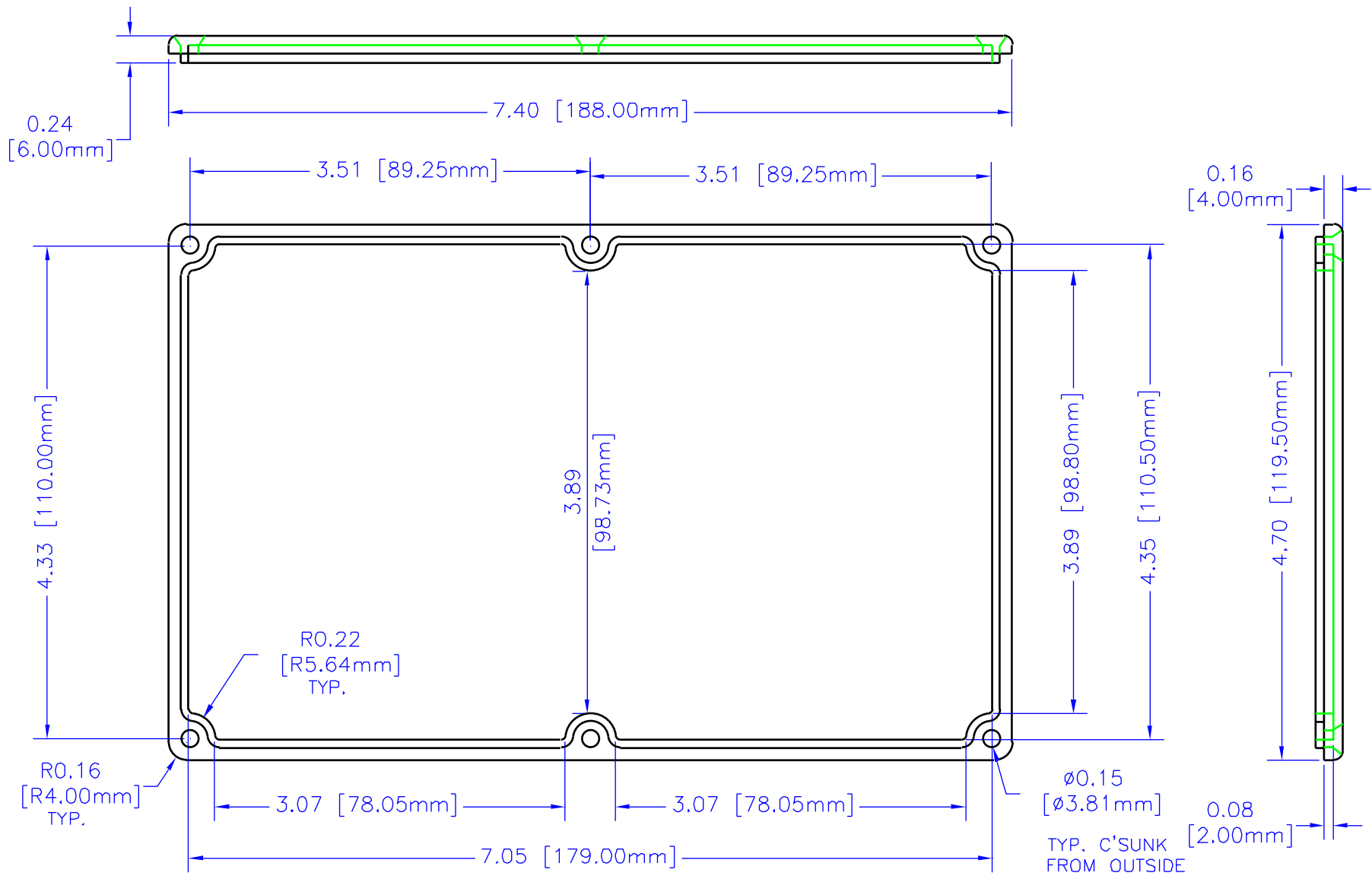

LID

UNLESS OTHERWISE SPECIFIED DIMENSIONS ARE IN INCHES	
X	+/- .1
XX	+/- .02
XXX	+/- .015
CLTS	+/- .005
ANGLES	+/- .5 DEG
NOTICE	
HAMMOND CLAIMS PROPRIETARY RIGHTS TO THE MATERIAL ON THIS DRAWING. IT IS INTENDED TO BE USED AS A REFERENCE FOR ENGINEERING INFORMATION ONLY. THIS INFORMATION MAY NOT BE USED TO MANUFACTURE PRODUCT WITHOUT WRITTEN PERMISSION FROM HAMMOND MANUFACTURING.	

HAMMOND MANUFACTURING

WEB: WWW.HAMMONDMFG.COM

TITLE		HAMMOND 1590 SERIES DIE-CASTED ENCLOSURE	
DRAWN BY	MJM	DATE	08/30/01
SCALE		PAGE	2 OF 2
PART NUMBER		1590E	