

REV	DESCRIPTION	DATE

NOTES

MATERIAL DIE-CAST ALUMINUM ALLOY 413(13)
PARTS ENCLOSURE BASE, LID AND EITHER 4, 6, OR 8 6-32X0.5" NICKEL PLATED MACHINE SCREWS, PAINTED BOXES COME WITH COLORED SCREWS. REPLACEMENT SCREWS ARE AVAILABLE, SEE CATALOG FOR DETAILS.
OPTIONS WATER RESISTANT SILICONE SEAL BY ADDING THE LETTER "W" AFTER 1590 IN THE PART NUMBER. SILICONE TEMP. RANGE IS -62C TO 232C (-80F TO 450F)
FINISH UNFINISHED (NO SUFFIX), BLACK POWDER ("BK" SUFFIX), GRAY POWDER ("GY" SUFFIX),

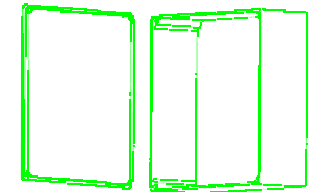
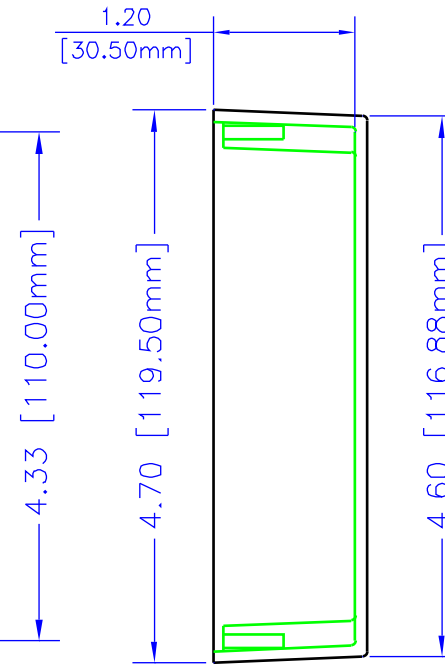
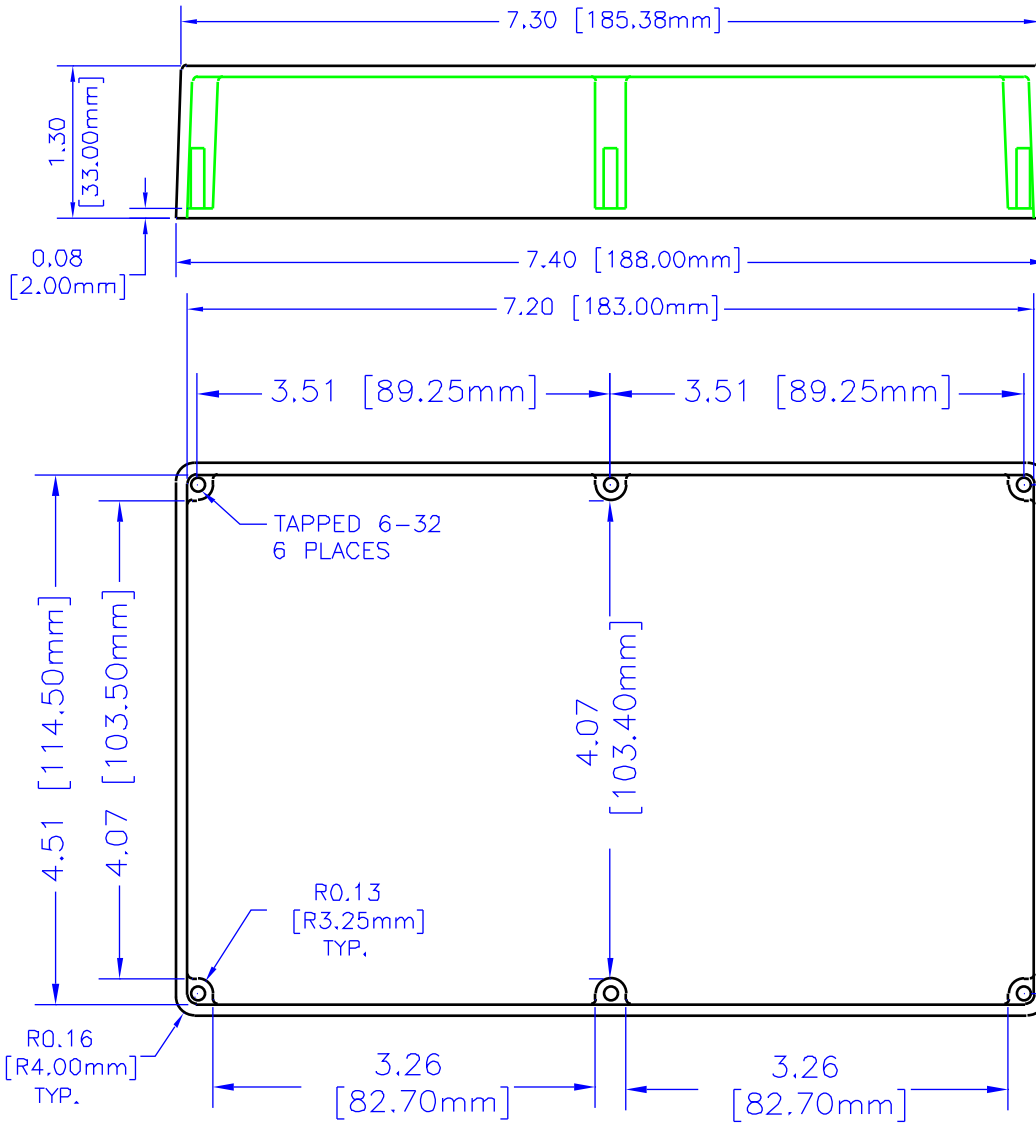

3D VIEW
(NOT TO SCALE)

BOX

UNLESS OTHERWISE SPECIFIED
 DIMENSIONS ARE IN INCHES
 .XX +/- .1
 .XXX +/- .02
 .XXXX +/- .015
 .XXXXX +/- .008
 ANGLES +/- .5 DEG

NOTICE
 HAMMOND CLEARING PRODUCTS REFERS TO THE MATERIAL ON THIS DRAWING. IT IS INTENDED TO BE USED AS A REFERENCE FOR ENGINEERING INFORMATION ONLY. INFORMATION MAY NOT BE USED TO MANUFACTURE PRODUCT WITHOUT WRITTEN PERMISSION FROM HAMMOND MANUFACTURING.



**HAMMOND
 MANUFACTURING**

WEB: WWW.HAMMONDMFG.COM

TITLE
 HAMMOND 1590 SERIES
 DIE-CASTED ENCLOSURE

DRAWN BY MJM DATE 08/25/01
 SCALE PAGE 1 OF 2
 PART NUMBER 1590DD

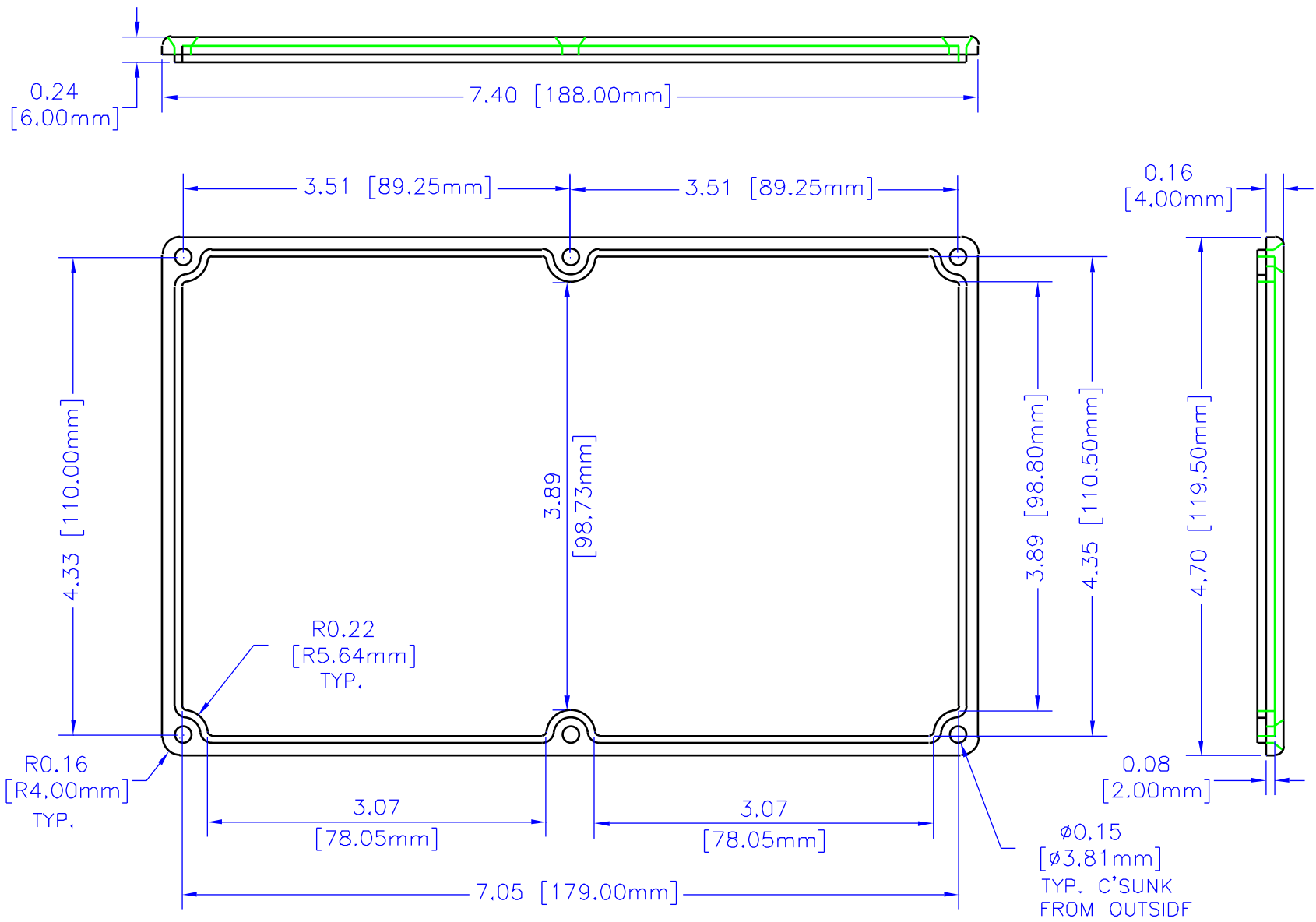

LID

UNLESS OTHERWISE SPECIFIED	
DIMENSIONS ARE IN INCHES	
∅	+/- .01
xx	+/- .02
xxx	+/- .013
PLTS	+/- .005
ANGLES	+/- .5 DEG
NOTICE	
HAMMOND CLAIMS PROPRIETARY RIGHTS TO THE MATERIAL ON THIS DRAWING. IT IS INTENDED TO BE USED AS A REFERENCE FOR ENGINEERING INFORMATION ONLY. THIS INFORMATION MAY NOT BE USED TO MANUFACTURE PRODUCT WITHOUT WRITTEN PERMISSION FROM HAMMOND MANUFACTURING.	

HAMMOND MANUFACTURING

WEB: WWW.HAMMONDMFG.COM

TITLE	
HAMMOND 1590 SERIES DIE-CASTED ENCLOSURE	
DRAWN BY	DATE
MJM	08/25/01
SCALE	PAGE
	2 OF 2
PART NUMBER	
1590DD	