

REV	DESCRIPTION	DATE

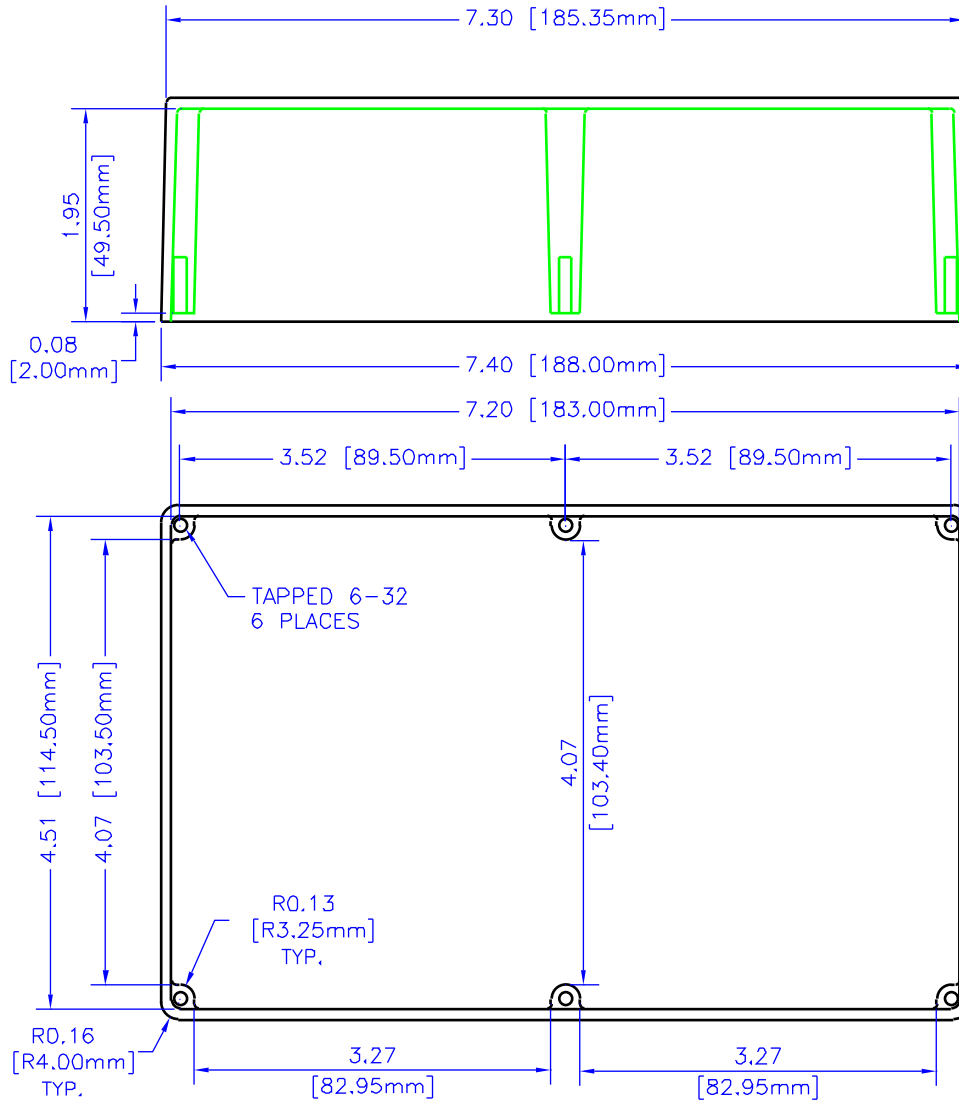

NOTES

MATERIAL DIE-CAST ALUMINUM ALLOY 413(13)
PARTS ENCLOSURE BASE, LID AND EITHER 4, 6, OR 8 6-32X0.5" NICKEL PLATED MACHINE SCREWS. PAINTED BOXES COME WITH COLORED SCREWS. REPLACEMENT SCREWS ARE AVAILABLE, SEE CATALOG FOR DETAILS.
OPTIONS WATER RESISTANT SILICONE SEAL BY ADDING THE LETTER "W" AFTER 1590 IN THE PART NUMBER. SILICONE TEMP. RANGE IS -62C TO 232C (-80F TO 450F)
FINISH UNFINISHED (NO SUFFIX), BLACK POWDER ("BK" SUFFIX), GRAY POWDER ("GY" SUFFIX),

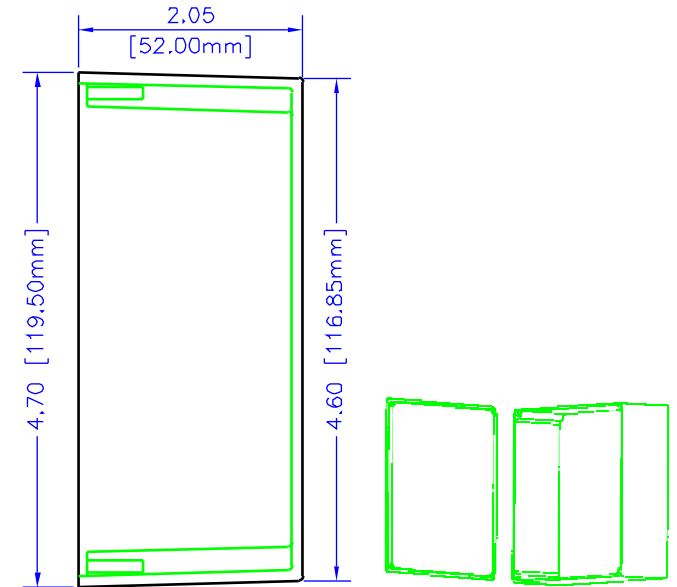

3D VIEW
(NOT TO SCALE)

BOX

UNLESS OTHERWISE SPECIFIED
DIMENSIONS ARE IN INCHES
X +/- .1
XX +/- .02
XXX +/- .015
CUTS +/- .005
ANGLES +/- .5 DEG



**HAMMOND
MANUFACTURING**

WEB: WWW.HAMMONDMFG.COM

TITLE
HAMMOND 1590 SERIES
DIE-CASTED ENCLOSURE

DRAWN BY MJM DATE 12/03/01

SCALE PAGE 1 OF 2

PART NUMBER
1590D

NOTICE
HAMMOND CLAIMS PROPRIETARY RIGHTS TO THE MATERIAL ON THIS DRAWING. IT IS INTENDED TO BE USED AS A REFERENCE FOR ENGINEERING INFORMATION ONLY. THIS INFORMATION MAY NOT BE USED TO MANUFACTURE, REPRODUCE OR OTHERWISE PERFORM WITHOUT WRITTEN PERMISSION FROM HAMMOND MANUFACTURING.

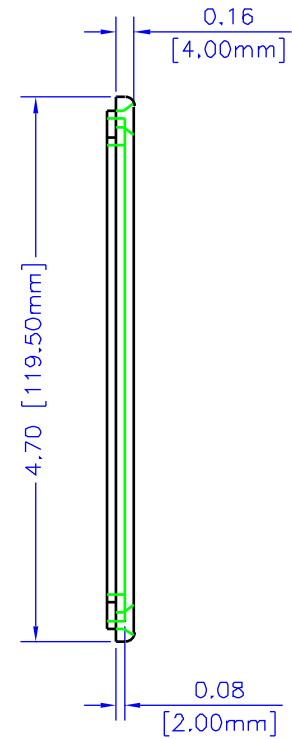
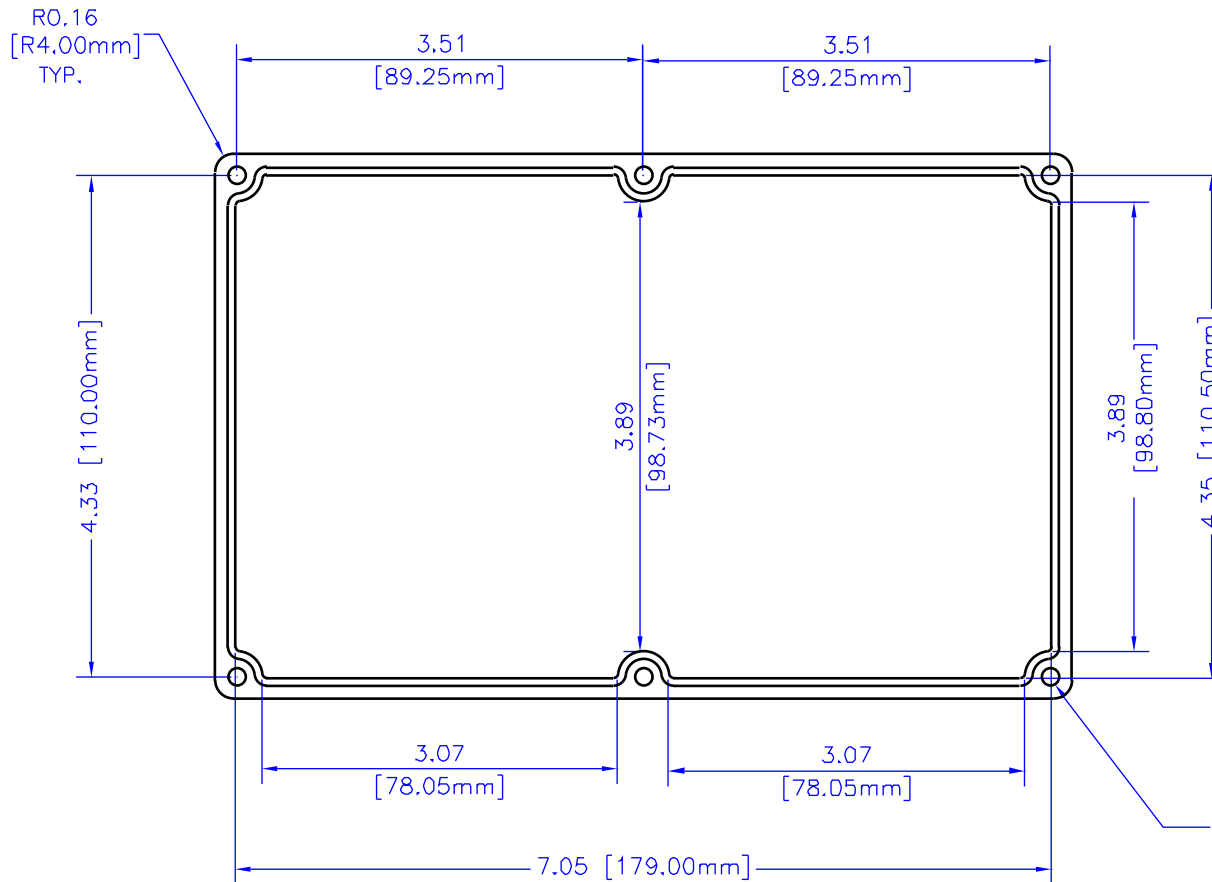
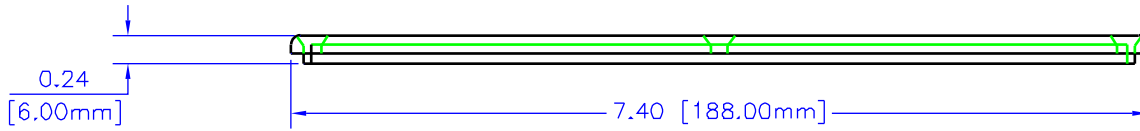

∅0.15
[∅3.81mm]
TYP. C'SUNK
FROM OUTSIDE

LID

UNLESS OTHERWISE SPECIFIED
DIMENSIONS ARE IN INCHES
K +/- .1
XX +/- .02
XXX +/- .015
CUTS +/- .005
ANGLES +/- .5 DEG.

NOTICE
HAMMOND MANUFACTURING PROPRIETARY RIGHTS IN
THE MATERIAL OF THIS DRAWING IS SO
INTENDED TO BE USED AS A REFERENCE FOR
ENGINEERING INFORMATION ONLY. THIS
INFORMATION MAY NOT BE USED TO
MANUFACTURE PRODUCTS WITHOUT WRITTEN
PERMISSION FROM HAMMOND MANUFACTURING



**HAMMOND
MANUFACTURING**

WEB: WWW.HAMMONDMFG.COM

TITLE
HAMMOND 1590 SERIES
DIE-CASTED ENCLOSURE

DRAWN BY MJM DATE 12/03/01
SCALE PAGE 2 OF 2

PART NUMBER
1590D